

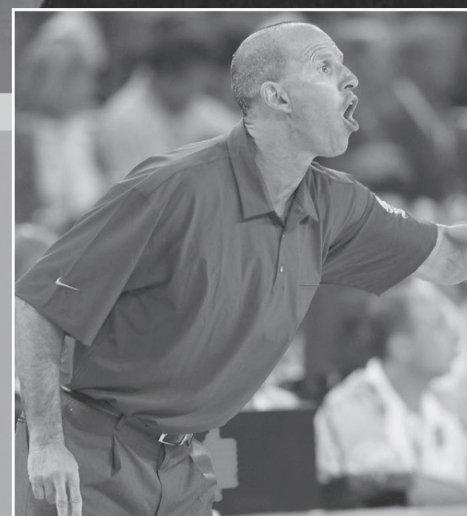

BASKETBALL COACHING MADE EASY



INTRODUCTION, ROLE OF THE
COACH, INCLUSIVE COACHING
AND SPORTS SCIENCE



Basketball Australia formed in 1939

Member

INTERNATIONAL BASKETBALL FEDERATION (FIBA), FIBA OCEANIA, COMMONWEALTH BASKETBALL FEDERATION, AUSTRALIAN OLYMPIC FEDERATION

Patron: The Hon. John Howard MP Prime Minister

President: John Maddock

Chief Executive: Scott Derwin

General Manager, Community Basketball: Michael Haynes

Manager, National Player and Coach Development: Patrick Hunt

STATE/TERRITORY ASSOCIATIONS

Australian Capital Territory, New South Wales, Northern Territory, Queensland, South Australia, Tasmania, Victoria, Western Australia

LEAGUE ASSOCIATIONS

National Basketball League, Women's National Basketball League, Australian Basketball Association

LIFE MEMBERS

Dr I. Burge (deceased); A.M. Ramsay, MBE; Mr. K. Watson, BEM;
Mr. R Staunton, OAM (deceased); Mr. G Russell, OAM; Mrs. B Watson;
Mr. J Small, OAM (deceased); Mr. R Kidner; Mr. W Feltham; Dr J. Raschke, OAM (deceased); Mr. A. McRobbie, OAM (deceased); Mr. K. Madsen; Mr. R. Butler; Mr. L.Gaze OAM; Mrs. L.Landon; Mr. R.Elphinston; Mr. M. Speed;
Mr. R. Harvey CVO, AM; Dr. A Hurley; Mr. J Martin.

COMMISSIONERS

DEVELOPMENT – Mr. Darryl Durham; TECHNICAL OFFICIALS – Mr. John Martin; COACHES – Mr. Warwick Cann

The National Coaching and Accreditation Scheme (NCAS) was established in 1978 with the primary aim of up-grading and expanding coaching expertise across a wide range of sports. Basketball Australia has embraced this scheme since its inception.

This Level 1 Manual is a substantial revision on previous editions and many thanks are due to Mr Ian Ellis for his work as well as the numerous other coaches who have been kind enough to have input. The manual remains the basis of Basketball Australia's NCAS Level 1 course however has been produced in separate booklets to make it easier for coaches to identify specific information they are after.

This manual is not designed to have all coaches around Australia doing the same thing, rather it is to allow coaches at all levels to perform more effectively and constructively. The application of knowledge remains flexible according to the talent and ability of the individual coach and the athletes they are working with.

Good luck with your coaching!

Basketball Australia would like to acknowledge the assistance from FIBA Oceania and the Australian Sports Commission in the production of the *Coaching Made Easy* series.

Copyright by: Basketball Australia. All rights reserved 2005.

Basketball Australia

PO Box 7141 Alexandria NSW 2015
Level 3, 256 Coward Street Mascot NSW 2020
Telephone: (02) 9469 7200 Fax: (02) 9469 7201
www.basketball.net.au



One Basketball Canberra

PO Box 3268
Belconnen ACT 2617
Telephone: (02) 6253 3066 Fax: (02) 6253 3060
www.act.basketball.net.au



NSW Basketball Association Ltd

PO Box 198
Sydney Markets NSW 2129
Telephone: (02) 9746 2969 Fax: (02) 9746 1457
www.nswbasketball.net.au



Basketball NT

PO Box 42240
Casuarina NT 0810
Telephone: (08) 8945 3761 Fax: (08) 8945 3862
www.nt.basketball.net.au



Queensland Basketball INC

PO Box 1281
Milton QLD 4064
Telephone: (07) 3377 9100 Fax: (07) 3371 7239
www.basketballqld.net.au



Basketball Association of South Australia

PO Box 29
Findon SA 5023
Telephone: (08) 8444 6444 Fax: (08) 8444 6488
www.sa.basketball.net.au



Tasmanian Basketball Association (Inc)

PO Box 21
New Town TAS 7008
Telephone: (03) 6331 4287 Fax: (03) 6332 7896
www.tas.basketball.net.au



Basketball Victoria (Inc)

Box 3, MSAC
Aughtie Dr, Albert Park VIC 3206
Telephone: (03) 9927 6666 Fax: (03) 9927 6677
www.basketballvictoria.com.au



Basketball WA (Inc)

PO Box 185
Floreat WA 6014
Telephone: (08) 9284 0555 Fax: (08) 9284 0550
www.basketballwa.asn.au



INTRODUCTION

Australia has a proud history in basketball and in 2004 was ranked 3rd amongst all nations. This success is due in no small way to the tireless work of coaches throughout the country, from “learn to play” programs right through to the Boomers and Opals.

The National Coaching and Accreditation Scheme (NCAS) was established in 1978 with the primary aim of up-grading and expanding coaching expertise across a wide range of sports. Basketball Australia has fully embraced this scheme since its inception and has developed, in conjunction with the Australian Sports Commission, a systematic and on-going educational program for basketball coaches.

Basketball Coaching Made Easy has been formulated to provide the background of knowledge and expertise for aspiring Level 1 basketball coaches. This course applies covers general coaching principles and applies them specifically to basketball, with an emphasis on having sound knowledge of the skills and principles of basketball as well as better organisation of practice sessions, appropriate methods of teaching and correcting techniques and methods of analysing an athlete's performance.

There is a wealth of resources available to coaches – a simple search on the internet will identify many hundred websites with an amazing array of information. There are books and videos on all aspects of basketball coaching and a visit to the National Sports Information Centre at the Australian Institute of Sport is a must for any coach visiting Canberra. Indeed your local library is often a great source of coaching material.

With all this information available a coach could easily find enough drills to fill many years of training sessions! Drills are the “tools of the trade” for coaches but the art of coaching is about the teaching points that you highlight in a given drill. Coaches must focus on the teaching points as these are what make their players better!

The National Intensive Training Centre Program is the key component of Basketball Australia's national player and coach identification and development strategy. There are full time coaches in each state and territory who deliver the program with the assistance of a strong network of coaches. The NITCP has a heavy emphasis on developing individual offensive and defensive fundamentals as well as team principles of play. Coaches interested in learning more about the NITCP should contact the head coaches through their state associations.

Whether you are coaching a team of beginners who are just learning to love the sport or a representative team “Basketball Coaching Made Easy” has information relevant to you. For further information on coaching clinics or resources contact your State/Territory Association or log onto the Basketball Australia website, www.basketball.net.au.

Books 1 to 5 of *Basketball Coaching Made Easy* are the text for the basketball component of the Level 1 NCAS Course.

Enjoy your coaching!



LIST OF CONTENTS

Chapter 1: History of Basketball – An Overview	7
Where it all began	7
The International Scene	7
The Australian Scene	7
Chapter 2: The Game of Basketball	9
Playing Positions	9
The playing court	10
Equipment	11
Teams	12
Uniform	12
Rules of the game	12
Chapter 3: Role of the Coach	17
Coaching styles	18
Developing a coaching philosophy	19
Becoming a respected coach	20
Developing a season plan	22
Practice session content	23
The “nitty-gritty” of coaching	27
Organising athletes at training	28
Evaluating skill performance	31
Managing efficient training sessions	32
Coach-Referee relations	32
The legal responsibilities of coaching	33
Ten important duties of any coach	34

Chapter 4: Basketball for People with a disability	36
Role of the coach	36
Developing an inclusive philosophy	36
Planning to include	37
Observation and questioning	38
Basketball for Players with an Intellectual Disability	42
Chapter 5: Sports Science	43
Components of fitness	43
Principles of training	44
Fitness training and stretching	46
Warm up and cool down	46
Stretches for basketball	48
General conditioning circuit for basketball	49
Sports safety	50
Basketball injuries and treatment	51
Injury management	53
Sports psychology	55
Glossary of terms	63
Index	68

CHAPTER 1: HISTORY OF BASKETBALL - AN OVERVIEW

Where It All Began

In November 1891, Dr Luther Halsey Gulick, the Director of Physical Education at the School of Christian Workers in Springfield, Massachusetts, searched for an idea for a winter sport. This would be designed to alleviate the problem of providing opportunities to participate in a sport when conditions outside were well below zero.

Dr James Naismith, in December 1891, was to answer Gulick's search with a new sport named "Basket Ball", a game where skill and precision outweighed the effort and strength required in rugby, the popular sport at the time.

The first game of basketball was based on two central ideas. A ball to be thrown with the hands and a goal to be placed up high. The first goals used were peach baskets, 10 feet off the floor at each end, which is still the current height of the ring today. Two sides made up of nine players each played the first game. It is obvious that with eighteen players all from rugby background that this game was characterised by rough play and plenty of fouls.

Only thirteen rules applied in the initial game, however dribbling was not one of them. A player had to "throw" it from the spot on which he catches it, allowances to be made for a man who catches the ball running if he tries to stop. Initially players were allowed only two fouls, which often meant players fouled out quickly. The only way they could re-enter the game was once their team scored, and with very low scoring games, this was rare.

On the 11th March 1892, with a crowd of over 200, the first official game of basketball was played between the teachers and students of the YMCA at Springfield.

The International Scene:

Basketball is an Olympic sport and shares one of the highest international profiles. Along with Soccer it is the most widely played team sport in the world. Australia has seen a rapid development of basketball particularly over recent years. It's growth and success internationally has put Australia on the map as a world power within the sport.

In 2003, 212 countries were affiliated with FIBA – the international basketball federation. Following the 2004 Athens Olympic Games, Australia was ranked by FIBA as the 3rd nation in the world.

The Australian Scene:

Basketball spread quickly worldwide. By 1893 it had spread to France and other parts of Europe and by 1896, China and Asia. The YMCA was a principle force behind spreading the game internationally.

The game was to flourish in Victoria and quickly expanded into NSW where it moved into Church Halls and particularly Presbyterian and Church of England. 1931 saw the establishment of the Victorian Basketball Association (VBA) with Ivor Burge largely responsible for bringing both the YMCA and church groups together under one banner. In 1938 the NSW Basketball Association was formed thanks to Jack Snell and Eric Calloway.

The Amateur Basketball Union of Australia was established in 1939. This was to be the forerunner to the current Basketball Australia. During the Second World War, basketball virtually went into recess apart from an odd game between Australians and visiting American servicemen.

Basketball became a truly national sport in 1946 with the first National Men's Championships played in Sydney. NSW defeated Victoria 50 – 44. The women had to wait until 1955 for their first National Championship, where South Australia defeated New South Wales 50 – 34.

Australia became the 52nd affiliated member of the International Basketball Federation (FIBA) in 1948. It was from here that basketball in Australia took on major change. Developments in equipment, and in particular facilities saw rapid improvements in the sport. 1956 saw important developments for basketball largely due to the Olympic games. Facility development saw tremendous improvements due to the need for better facilities to conduct the Olympics.

The 1960's saw the emergence of some Australian playing legends, many of whom paved the way for the development of basketball in Australia. Lindsay Gaze, John Raschke, Ken Cole, and Bill Wyatt were just a few of the stars of this period. Eddie Palubinskas came onto the international scene during the 1970's. His shooting feats during the Olympic games in Munich 1972 and Montreal 1976 and being drafted to the NBA in the same year focused international attention on Australia.

The National Basketball League (NBL) was established in 1979. The 1980's were a boom period for Basketball with enormous growth in popularity and participation. It was during this period that Australia was to make their mark on the international scene. Both the Australian men's and women's team placed 4th at the Seoul Olympic Games. While the women's youth team took bronze at the World Youth Championships held in Spain in 1989.

With international success and the popularity of basketball rapidly increasing, an exciting time throughout the 1990's was expected. International success was again a feature with the Australian men's and women's teams placing 7th and 6th at their respective world championships. 1992 saw the Australian men finish a very respectable 6th at the Olympic Games in Barcelona.

Gold! Australia's first gold medal came on the international scene in 1993. The Australian women's youth team won gold at the World Championships in Korea. At the same time the Australian men's youth team came 8th in the first World Championship for players 23 and Under.

It was obvious that Australian women's basketball was extremely competitive internationally with a 4th placing at the 12th Women's World Championships held in Australia in 1994. The men placed 5th at the World Championship held in Toronto, Canada.

1995 and 1996, again saw fantastic results internationally. The Australian Youth Men's team, the "Emus" won a silver medal in the 1995 World Championships. And their senior counterparts, the Boomers, equalled their best ever Olympic result coming fourth in Atlanta in 1996. The Australian Opals Womens Team went one better, winning a bronze medal at Atlanta.

Continued growth and success was realised in 1997 when the Under 23 Men's squad captured gold at the World Championships, hosted in Melbourne. In 1998, the Women's World Championships held in Germany yielded another bronze for Australia's Opals.

Hosting the 2000 Olympics in Sydney, Australia maintained their high standing on the international arena. The Boomers repeated their 4th position in Atlanta, following the bronze medal play off against Lithuania. The Australian Opals Women's team continued to climb the international ratings with a silver medal in the play off against the USA.

In 2003 the Australian Emus Youth Mens team won gold at the World Championships and the Opals repeated their success winning silver again in the 2004 Athens Olympic Games.

Australian basketball continues to grow and see enormous success all round. Australia has truly become a powerful basketball nation. A good deal of the credit comes back to the work of coaches throughout Australia. The success internationally in many ways can be attributed to the coaches that work endless hours to develop basketball at both junior and senior levels

CHAPTER 2: THE GAME OF BASKETBALL

Two teams, with five players on the court at one time, play basketball. Teams are allowed to have another five players as substitutes and there is no limit on the number of times a substitution can be made. The object of the game is to score by putting the ball through the basket more times than your opponent. Players generally play positions known by the number listed below:

Playing Positions

- **Point Guard ("1"):** usually the main ball handler within the group. This player is primarily responsible for moving the ball down the court. Also known as a perimeter player as most of their work in offence will be done from behind the three-point line.
- **Off or Shooting Guard ("2"):** usually the player with secondary responsibility for moving the ball down the court. Primary role is to be a scorer and this would occur mainly from the perimeter.
- **Small Forward ("3"):** this player is also known as the "swing" player in that they have to be able to play both areas, on the perimeter or in the post. Ability to score from the post or from the perimeter is a priority.
- **Power Forward ("4"):** usually the power player in the team. Primarily a post player that should be able to operate from the perimeter. This player should be one of the main rebounders with strong blocking out skills.
- **Centre ("5"):** usually the biggest player on the team. Primarily a post player, however, should learn and have the ability to play on the perimeter. The main rebounder and power player within the key.

Basketball has developed to the stage that all players need a range of skills no matter what their physical disposition may be. Therefore, it is essential from a young age that all players experience playing a variety of positions. Each player requires a diverse range of skills. It is essential that every coach provide the necessary skills to allow each participant to maximise their potential.

The Basket

Regulation Backboard:

The backboard should be made of suitable transparent material or hardwood 3cm thick.

The front surface of the backboard shall be flat. All lines should be 5cm wide.

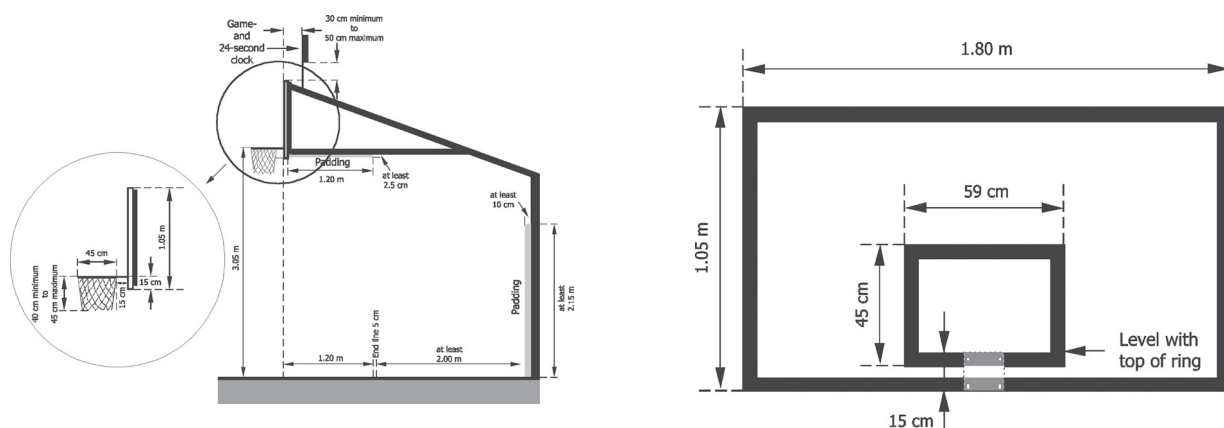

Regulation Ring:

Solid iron with a 0.45cm inside diameter painted orange.

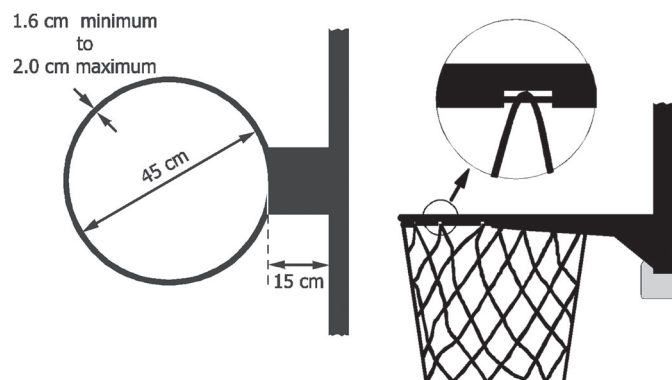

The Ball

The ball should be spherical. The outer surface may be made of leather, rubber or synthetic material.

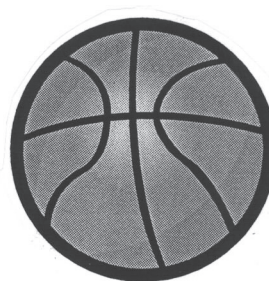

Teams

Each team may consist of up to 10 players. Only 5 of these players may take the court at any one time. Each player must be appropriately attired before commencing play. A player may enter a game by way of substitution. This occurs when a player on the bench is substituted for a player on the court. The player coming into the game reports to the score bench, who at the appropriate time, will notify the referees. A referee will then acknowledge the sub and call that player on, to substitute for a player on the court.

Playing Uniform

Players should wear the appropriate team uniform. This must be of uniform design and colour. Shorts, singlets, and in some cases body suits, are the desirable uniform to be worn. No player is allowed to take the court without a number. This number should be visible on the singlet. (Note: taped numbers are usually not permitted.)

Footwear should consist of basketball shoes with non-marking soles.

Players must remove watches and jewellery before playing, as these can cause injury to others during the game.

Rules of the Game

This section includes a brief outline of the major rules in the game of basketball. In no way should this be considered a rulebook as changes to the rules occur yearly. The rules included are current for the time of publication. For further information on rules, and in particular, further technical interpretation consult the Official Basketball Rules and Referee's Manual available from your State Association.

The game is started with a jump ball. One player from either team stands in the centre circle, facing the basket they are trying to score in. The umpire throws the ball up, and both players jump and attempt to tap it to one of their teams mates.

One team gains possession following this jump ball and the "possession arrow" points to the other team. At the start of each quarter, the team that has the "possession arrow" throws the ball in to start the quarter.

The possession arrow also determines who gets the ball when two players jointly have possession (a jump ball was formerly taken by the two players).

There are three major rules in the game of basketball. These include:

- Violations
- Personal fouls
- Technical fouls

Violations

When a violation occurs the team in possession of the ball immediately loses possession and the ball is awarded to their opponents. The ball is then taken out of bounds at the closest point to the infraction.

Types of violations include:

- Ball out-of-bounds
- Dribbling violation
- Travelling violation
- Three second violation
- Five second violation
- Eight second violation
- Twenty four second violation
- Back court violation
- Goal tending violation

Ball Out of Bounds:

The ball is ruled out of bounds when it touches a player, floor, or object above or outside the boundary line. The last player that touches the ball prior to it going out is responsible and the opposing team is rewarded the ball. If the ball lands on the boundary line it is out of bounds.

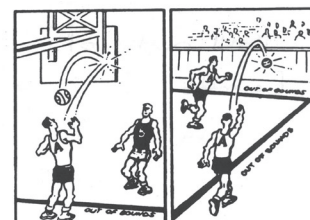

Dribbling violation:

A player shall not dribble the ball a second time after their first dribble has ended. The dribble is completed after the player touches the ball simultaneously with both hands, or permits the ball to come to rest in one or both hands. Dribbling with two hands is also a violation.

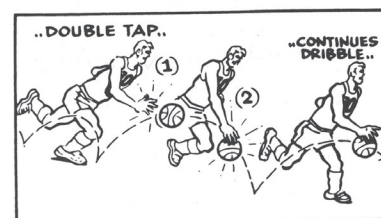

Travelling violation:

A player who has possession of the ball must not run with the ball. It is a violation to take more than one step while the ball is held.

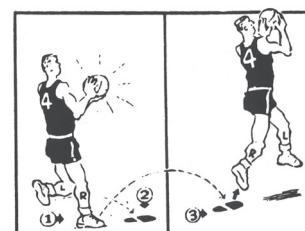

Three Second violation:

When a team has possession of the ball each player in the offensive team is not allowed inside the key at their scoring end for longer than three seconds. This includes the lines marking the keyway. This rule does not apply when the ball is in the air for a shot at goal, during a rebound or when the ball is dead.

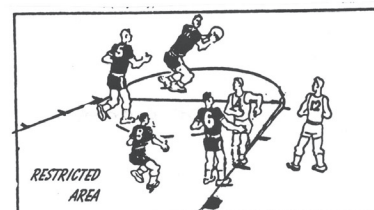

Five Second Violation:

When a player has the ball and is closely guarded they must pass, shoot or dribble the ball within five seconds. If they don't it is a five second violation.

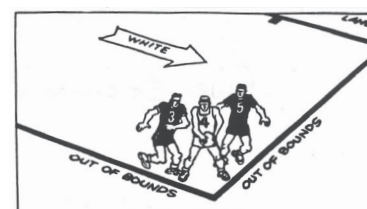

Eight Second Violation:

This violation results from a team gaining control in the back court, their defensive end. The offensive team has eight seconds to move the ball from the back court to the front court. The ball has moved into the front court once it touches the front court or a player in that area.

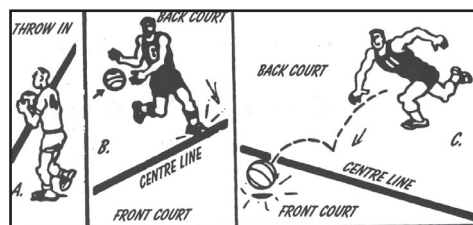

Twenty Four Second Violation:

A team in possession of the ball has twenty four seconds to attempt a shot for a field goal. If the shot misses it must make contact with the ring to be recognised as a legitimate shot. If it did hit the ring, the shot clock is re-set. This rule is not enforced in many local competitions.

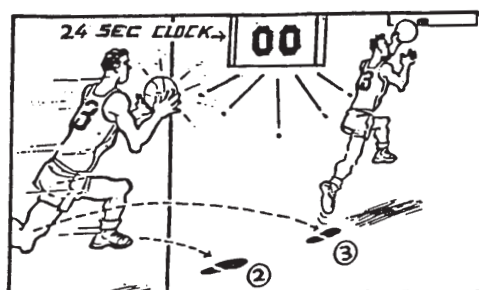

Back Court Violation:

When a team has possession of the ball in their front court or (offensive end) they must not allow the ball to go back into their back court (defensive end). This rule applies only if a team has control of the ball and is the last to touch it in their front court before it rolls or goes into their back court. If a player on the same team touches the ball in the back court a violation will result.

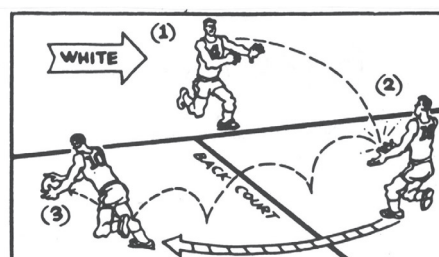

Goal Tending Violation:

An offensive player or defensive player must not touch the ball while it is in its downward flight and above the level of the ring during a shot for a field goal. This applies up until the ball touches the ring or it is evident it will not touch the ring.



Personal Fouls

Basketball is designed as a non-contact sport, however, when 10 players on one court are playing at high speed, all with a strong desire for the ball, contact is inevitable. A personal foul is a player foul which involves contact with an opposing player, whether or not the ball is in play. This type of foul is a result of a player blocking, holding, pushing, tripping, or impeding the progress of an opponent by extending their arm, shoulder, hip, knee, or foot. The result in the infringement of the above rule will be the following personal fouls:

Blocking:

Personal contact which impedes the progress of an opponent.

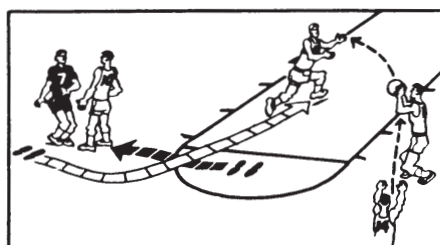

Charging:

Personal contact, with or without the ball, by pushing or moving into an opposing player's torso.

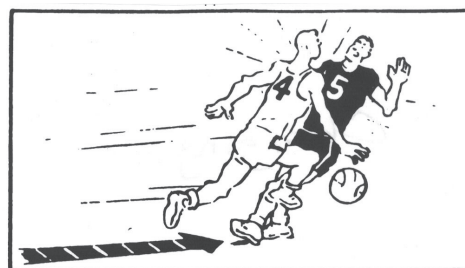

Hand checking:

Is the action by a defensive player in guarding situation where the hand(s) are used to contact an opponent to either impede their progress or to assist the defensive player in guarding their opponent.

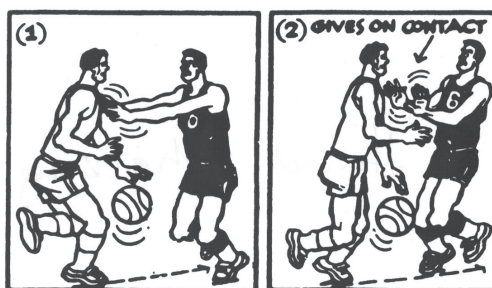

Holding:

Is personal contact with an opponent that interferes with their freedom of movement. This contact can occur with any part of the body.

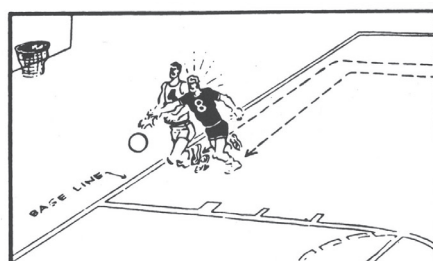

Illegal Use of Hands:

Occurs when a player contacts an opponent with their hand(s) in an attempt to play the ball. If such contact is only with the opponent's hand while it is on the ball, it shall be considered incidental and is not a foul.

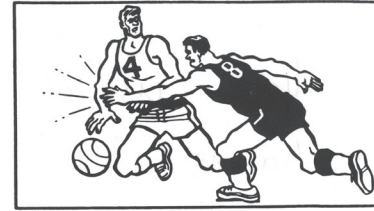

Pushing:

Is personal contact with any part of the body that takes place when a player forcibly moves or attempts to move an opponent who has or does not have control of the ball.



Illegal Screening:

Is an attempt to illegally delay or prevent an opponent who does not control the ball from reaching a desired position on the playing court.

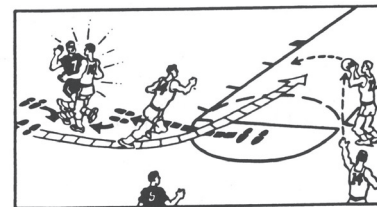

Technical Fouls

Basketball is a game designed around participating with proper conduct. Officials, coaches, players, substitutes and team followers, should be attempting fair play in the true spirit of sportsmanship.

A Technical Foul by a player may result from the following :

- Disrespectfully addressing or gesturing at other players, officials, coaches, spectators.
- Deliberately delaying the game by preventing a throw in.
- Changing their player number without reporting to the score bench.
- Grabbing the ring in such a way that the ring supports the weight of the player. This may be allowed only if the player is trying to prevent injury to themselves or another player.

A technical foul by a player will result in one free throw being awarded to the opposition, followed by possession of the ball at mid-court.

A Technical Foul by a coach, substitute or team follower may result from the following :

- Coach or assistant coaches entering the playing court without permission from the official.
- Disrespectfully addressing or gesturing towards the officials, technical commissioner, scorers, timekeeper, 30 second operator or opponents.

A technical foul by a coach, substitute or team follower will result in two free throws being awarded and followed by possession of the ball at mid-court.

If two technical fouls are directly attributed to the coach, or three technical fouls accumulated by the assistant coach or team bench, the coach is disqualified and must leave the game and go to and remain in their teams dressing rooms for the duration of the game or, if they so choose, they can leave the building.

CHAPTER 3: ROLE OF THE COACH

As a basketball coach you will be faced with many challenges and responsibilities. You will be faced with a wide variety of roles. Assistance is often required to fulfil many of these roles and a coach should be ready and willing to seek help where appropriate. Appointing a team manager and assistant coach, or asking for help from parents or club officials, can be very useful in assisting a coach to complete their duties with relative ease. Whatever help is sought it is vital that the coach defines roles for the staff working for them. This will mean that each person will have a specific task and direction in which they need to work.

The following is a list of some of the roles that a coach may be faced with.

Organiser: An essential task for any coach is to organise and coordinate their team. Areas such as practice times, venue arrangements need to be organised. This will ensure that everyone involved clearly understands what is required and the program will run smoothly.

Teacher: A coach needs to be able to pass on information and ideas. Players are very similar to students in that they are always seeking new information to continually improve their game.

Student: No matter what level you are coaching, there is always something new to learn about basketball. It is important to watch, ask questions, listen and continually learn from what others are doing and your own personal experiences.

Planner: To plan is to ensure that everything you want covered and completed is done. Coaches who take time to plan will be far more organised and are more likely to achieve their objectives.

Trainer: Coaches at some time or other will be involved in improving an athlete's fitness. Coaches at elite levels become particularly involved in this area. Further courses are available in this particular area.

Public Relations

Officer: A coach must be able to communicate and promote their basketball programs, their club and their team. Coaches have the responsibility of dealing with a variety of people, including, parents, officials, sponsors, players, and community members. Therefore, it is important to conduct oneself professionally.

Motivator: All coaches at times need to be motivators. This will instill a positive, resolute approach in their players.

Disciplinarian: A firm but fair approach is essential for any coach. Too much discipline can hinder player coach relationships. It is important to have the right mix.

Friend: Basketball can be a very emotional sport and at times players need someone to whom to turn. Often a coach can help and provide assistance for players. The coach may be the person they trust and respect the most. Again there is a fine line, and it is important for coaches not to get too heavily involved.

Scientist: Coaches analyze, test and evaluate constantly to get the best method of coaching and style of play possible. It is often good to evaluate your coaching methods and often players give you the best insight into this.

Fund Raiser: For many teams to survive or compete in the various competitions and tournaments in which they compete in, they need income. An important part of this is fund raising.

Leader: It is important for all coaches to display leadership. It is the coach that players will look towards in crisis times. Coaches set the agenda, determine priorities and provide direction for their players.

Role Model: As a coach you are directly influencing the players within your team. It is important for you to act in a responsible manner. The behaviour of coaches often determines the behaviour of their players

Improving Performance: A major role for any coach is to improve each athlete's performance. Coaches should focus on the needs of each player, not just decide what tactics the team, as a whole will employ.

Coaching Styles

Coaching styles vary greatly, from a win at all cost attitude, at one end of the scale, to the laid back approach at the other. Whatever style coaches adopt will be quickly noticed by their athletes and may result in their players adopting a similar approach to playing.

The coaching styles that have been identified include.

1. Authoritarian coach

- This style of coach will be characterised by discipline and command.
- They may be strict and punish players regularly.
- Good team spirit will be displayed when winning, while dissension maybe shown when losing.
- Further, this style of coach will have the personality to handle being disliked in order to gain respect.

2. Business-like coach

- The style of coach who is keen on seeing the job done.
- Someone that demands a 100% effort at all times.
- A coach who is not people oriented who simply wants to get on with their job.

3. "Nice Guy" coach

- A style of coach that gets on well with athletes.
- One who considers heavily the wishes of players.
- They are usually characterised by having a quiet, cooperative nature

4. Intense coach

- A coach very similar to the authoritarian style, except without the discipline.
- This coach displays a strong desire to win and will demand plenty from their players.
- Often this style of coach becomes anxious and uptight if things do not go right.

5. Easy Going Coach

- This coach can be characterised by being very casual and submissive.
- Often laid back this style of coach can give the impression of not being altogether serious.
- On the bench the coach will often be seen sitting with only limited or no instruction.

It is important for each coach to adopt a style that suits their personality. It is likely that a coach's style may be a combination of styles.

Developing A Coaching Philosophy

To become a truly successful coach you must first develop a coaching philosophy. This involves a thorough understanding of why you coach and why your athletes play. It also involves listening and considering opinions of others, then developing and communicating your philosophy. For the athletes participating in your basketball program, their coach largely determines the quality of experience.

The first question when developing your philosophy is why coach? No doubt there are many reasons why you coach. These may vary from a personal love of the sport at one extreme, to winning at all cost at the other. The following are some reasons why people decide to take up coaching:

- Love of Sport
- Participation
- Played, and wish to put something back into the sport
- Friendship
- Helping others
- Enjoyment, of competition
- Satisfaction, of seeing athletes grow into better players and people.

Most coaches can identify with at least one of these, and obviously there are more. It is important for you to understand your own motivation, as this will impact on your development as a coach.

Whatever the reason, coaches must always take into consideration the needs, hopes, ambitions, personalities and personal desires of their athletes. It is essential to attempt to cater for various individual differences so that all athletes have the opportunity to reach their potential.

Why Do Athletes Take Part in Sport?

It is important for all coaches to take into consideration the needs and wishes of their athletes. It is likely that if this is understood, conflict and misunderstanding are less likely to occur in the future. Often coaches don't consider that some players are simply there to enjoy participating. In this instance a coach needs to understand the participant's wishes and treat them accordingly. Often coaches can be far too demanding of participants, when all they wish to do is enjoy the sport. Other participants may be there to develop and progress within the sport and may wish to be pushed to improve their skills.

Therefore, it is important as a coach to understand that each player is different and each has his or her own goals in relation to the sport. As a coach you must work towards providing the best experience for each and every participant so they may reach their hopes, dreams and ambitions.

The following is a common list of reasons why athletes participate in sport:

- Achievement
- Friendship
- Social interaction within a group
- Trophies
- Participation
- Fitness
- To be the best

- To improve necessary skills
- To win

Regular feed back from players is a good way to ensure they are enjoying their experience. Coaches should look to communicate in this fashion either by asking questions or having players complete feed back forms.

Becoming a Respected Coach

To become a respected coach requires successful interaction with individuals and the development of an environment where individuals may realise their hopes, ambitions and potential.

Unfortunately many coaches believe, “good” coaches are domineering, aggressive and overly authoritarian individuals, demanding a “win at all costs” attitude from their athletes. Consequently, too many coaches believe that their ultimate success rests with projecting a style of behaviour that fits in with this commonly held stereotype. Nothing could be further from the truth.

In reality a respected coach exhibits a wide variety of behaviours, from being somewhat authoritarian at times, to passive and uninvolved at others. The key to this is for coaches to be themselves and be able to adapt their style and behaviour as different situations emerge. Coaches, sensitive to individual differences, will not unduly risk alienating their athletes. They will not demand the respect of the athletes; instead, they will seek ways to earn it.

What qualities should a coach develop that will earn them the affection and respect of their athletes? The qualities may be grouped under the following headings.

- Knowledge
- Organisation
- Effective Communication

Knowledge

To gain the respect of players, coaches and officials it is essential to have a sound knowledge of basketball, its rules, skills, safety guidelines and principles of play.

Organisation

Good organisation is a key to gaining respect. Athletes will have confidence in a coach who conducts well-run, interesting and systematic practices. Well-organised practices are enjoyable, promote learning and consequently improvement in athletic performance. Coaches who continually inform players about upcoming events, games and practices will clearly demonstrate their organisational skills.

Effective Communication

A coach’s ability to communicate directly influences the degree of improved performance within their athletes. It doesn’t matter how much knowledge a coach has, without communication they will not succeed.

To be an effective communicator, the coach needs to develop concise teaching points. Too many coaches focus on what drill to run, rather than what teaching points they want to convey.

There are several forms of communication that coaches should constantly work to improve and enhance. These include both **verbal** and **non verbal** forms. **Non verbal** forms such as body language, gestures, facial expressions, touching and voice characterisation are just as important as verbal communication. It is important for a coach to appear enthusiastic. Players are more likely to respond and be motivated towards carrying out the instruction. Further, it involves coaches both showing and controlling their emotions.

When communicating, it is important to be clear and to the point. Players often learn more effectively by focusing their practice efforts on one clearly understood element in relation to their performance. Often coaches attempt to communicate as much information as possible on a variety of subjects. This may create “information overload”.

Any method of communication should be built around a **“two way process”**. Coaches should seek regular feedback to ensure their players have clearly understood what is being taught. Ask athletes questions and encourage them to express themselves. This will help keep them motivated and alert to coaching directions.

Coaches should develop their **own style of communication**. Never try to be someone you are not. It is valuable to study other coaches, as you may gain valuable and useful ideas. Coaches must embrace new concepts while maintaining their personal philosophy.

It is important for coaches to be able to communicate with players, referees, other coaches and parents. A coach should ensure everyone is aware of game times, trainings, and other events. Often a newsletter can help. Be approachable as a coach; never isolate yourself through a lack of communication. Clearly identify your philosophies, plans and objectives. When coaching juniors, it is vital to gain parental support. This can be done by communicating with parents on a regular basis, providing them with feedback about their child. Additionally, the highest standards of conduct should be encouraged from all players.

Planning

It is essential that all coaches take time to prepare and plan to meet the objectives of their team and individual players. Planning should be based around meeting both short and long term goals specified within the overall season plan. These objectives should be clearly stated to provide clear direction for everyone involved in the program.

Planning should commence prior to the upcoming season. The coach outlines the long-term objectives which should be based on the coach’s overall assessment of individual and team talent available. For example, a long-term goal may be to teach every player to effectively dribble with his or her weak hand.

After identifying long-term objectives it is then important to identify short-term objectives that will assist in reaching the long-term objectives. These short-term objectives will form the stepping stones towards meeting progressive objectives and developing a successful program.

An essential element in the planning process is to format training sessions and game plans. These should be written down so that accurate records can be kept and the coach can easily refer to them while their session is in progress ensuring that teaching areas be covered.

Training sessions completed “off the top of the head” may sometimes prove effective, however it is common to walk away from these sessions knowing important matters have been missed which would have assisted in reaching short term objectives. Trainings are far more effective if they are written down before they begin. There is a wide variety of drills that can be used to emphasise teaching points. Planning allows the session to flow in a systematic fashion. It is important to review long term and short term goals on a regular basis and adjust the overall plan as necessary.

Developing a Season Plan

The first step in developing a season plan is to develop long term objectives for the team. The following is an example of a coaching plan.

Sample Coaching Plan

TEAM	Morwell Tigers
DIVISION	Under 16 girls
SEASON	May to September (20 WEEKS)

Long term objectives:

- | | |
|---|-----------------------------|
| 1. Good Team Spirit | 4. Man defence (full court) |
| 2. Man to man offence (1.3.1 alignment) | 5. Zone defence (2.1.2) |
| 3. Zone offence (1.3.1 alignment) | 6. Transition game |

Short term objectives **2. Man to man offence**

- | | |
|---|---|
| 1. Pass and cut (guard to forward pass) | 4. Shoot off pass (point, wing, baseline) |
| 2. Turn and shoot (high and low posts) | 5. Fake and drive (point, wing, baseline) |
| 3. Flash cut, drop step, lay-up (posts) | 6. Offensive rotation/balance |

Once the coach has broken down each of the long-term objectives, daily training sessions are then developed.

These plans and objectives need to be constantly reviewed. Some areas may improve more rapidly than others. Further changes may be necessary to cater for individual needs or areas that require special attention. The coach may need to modify plans, but should never lose sight of the overall plan.

Elements of a Practice Session

An effective practice session begins with thorough planning allowing the coach to meet the clearly stated objectives identified in the planing process. A coach should compile a list of objectives for each practice session. This may include skills to be practiced, specific drills with a time element for each drill. Refer to the example practice plan later in this chapter.

Prior to commencing a session the coach should ensure there are an adequate number of basketballs, drink bottles and a first aid kit. The coach should ensure that the playing environment is safe. It is good practice to have athletes bring their own drink bottles, or to have one drink bottle each, and to give them plenty of breaks for them to drink.

Practice Session Content

The following are some steps needed to run an effective training session.

Objectives

To be adequately prepared for each session the coach needs to determine:

1. Areas of skill learning or fine tuning to be practiced
2. Specific teaching points to be emphasised in teaching identified skills
3. Time allocation for each drill
4. Appropriate drills to highlight these teaching points

Warm Up

The first thing a coach needs to do when conducting a training session is to ensure that players have completed an effective warm-up. It is a good idea to supervise this warm-up to ensure everyone is adequately prepared for the session ahead. A warm-up may help prevent injury, or lessen the severity of any injury by raising the players' heart rates so that muscles become warm.

Traditional warm-up routines have been based around some form of activity, followed by a stretching period often lasting up to ten minutes. Essentially this meant warm-up and then cool down while you stretch. It is now important that brief activity is followed by a few stretches then followed by further activity.

Warm Up and Stretch

Many teams only have a one hour training session because court space is limited. A warm up does not have to be done on court. If you have the team perform their warm-up while the team before you is still on court, you then have the full hour to work on skills.

The following routine can be used to warm-up players in preparation for practice. These activities should be planned so that they are incorporated into the session. Often the warm-up will occur prior to the commencement of the session.

Initial activity - Any activity such as Body Movement Fundamentals, Skipping, Passing Drills, etc. All of these activities raise the participant's heart rate, and warm-up muscles. Often fun activities can be programmed into this part of a session.

Stretching - Major muscle groups and tendons. See Diagrams: calves, achilles, quads, hamstrings.

Activity - As for initial activity, again warm-up of the players.

Stretching - Major muscle groups. See Diagrams: groin, lower back.

Activity - Same as initial activity, slightly quicker activity to further warm the muscles.

Stretching - Upper body stretches. See Diagrams: arms, shoulders.

Warm-up and stretching for these muscle groups can be found in Chapter 5 - Sports Science, refer to the Section on Fitness, Training and Stretching.

It is a good idea to have athletes bring a towel to sit on when doing stretching on the floor. This avoids having sweat marks on the floor, which players may slip on.

Skill Learning

This is a major part of the training session that focuses on individual skill learning or team concepts. It is recommended coaches follow a set routine or order of progression when these skills are practiced at training, particularly for beginning players.

The recommended progression is as follows:

1. Body movement fundamentals
2. Ball handling
3. Dribbling
4. Passing
5. Shooting
6. Rebounding
7. Individual offensive fundamentals
8. Individual defensive fundamentals
9. Team offensive fundamentals
10. Team defensive fundamentals
11. Scrimmage

When coaches plan their training sessions they should aim to work their players on a selection of fundamentals from each of the skill areas. It is often difficult to cover every area during one training session. Therefore, it is important to plan so that each area is covered and areas missed can be identified to be included in later sessions. Using a variety of drills will ensure players do not become bored. Coaches never should underestimate athletes and should continually seek to challenge players with new skills and drills.

Practical Application

This part of the training session focuses upon applying the individual fundamental skills and then transferring them to game situations. During this time the coach may wish to provide players with instruction. Coaches should “coach on the run” and instruct their athletes without holding up the drill. Scrimmaging prior to skill learning may reinforce bad habits. It is particularly important for beginner athletes to focus more on skill learning than practical application.

Practical application does not have to be playing 5v5. By introducing rules the coach can emphasise practicing particular skills. For example to emphasise passing, introduce a rule that players cannot dribble the ball or that all players must touch the ball before a shot can be taken.

Cool Down

Athletes should spend considerable time cooling down. Essentially this means walking or jogging to slow down the muscles and then stretching out the major muscle groups. Players should develop a routine by which they take time at the end of each game or training session to get this done. This will help to alleviate the problem of stiffness and soreness the following day. This is particularly important where games have to be played in succession.

Again, cool down can be done off court to maximise the time on court.

Ending Practice

Here the coach can generally review the training session, answer questions and cover organisational details such as next training time and/or next game time.

Always Leave Training On A Happy Note

Sample Training Session Plan

Time	Skill	Drill	Comment
8 min	Warm Up & Stretch	Body Movement Fundamentals & Stretches	<ol style="list-style-type: none"> 1. Jog, Backpeddle, Grapevine, Vary pace running 2. Stretch — Thigh, Hamstring, Calf 3. Heal to Butt running, Basketball skips, Change direction, Quick jumps (4 on each line) 4. Stretch — Achilles, Gluteals, Groin, Lower back 5. Reverse pivots, Defensive slides, Defensive drop steps 6. Stretch — Mid back, Shoulder, Front shoulder
3 min	Individual Skills	Ball Handling	Waist Wrap, Fig 8 Wrap, Straddle Flip, Blur Fig 8 Dribble etc 15 secs for each Count number completed
5 min		Dribbling (Full Court)	Speed — up right, back left Hesitation — up right, back left Crossover Behind Back Between Legs Reverse On-side — up right, back left
5 min		Passing	Pig in the Middle 3 Lane Drill 3 Man Weaves
8 min		Shooting	Technique Reinforcement - shooting to partner (no ring) - pairs shooting (10 shots each, partner rebounding)
5 min	Individual Defence	1 on 1 Corridor	Defending the dribbler - turning the dribbler - channeling the dribbler - slide, run, slide recovery
5 min	Team Offence	Forward Lead & Backdoor	1 on 0, into 1 on 1
7 min		Pass & Cut	Guard to Forward - 2 on 0 into - 2 on 1 into - 2 on 2
5 min	Transition	2 on 1 Fast Break	Full Court
5 min	Team Defence	Defend Flash Cut	Break Down Drill to practice defending weak side flash cut to ball
8 min		Shell Drill	4 on 4 to practice - player movement off the ball - help & rotation
7 min	Team Offence	3 on 3 or 4 on 4	Half court modified game (no dribble inside 3 pt line) Emphasis on: - leads & backdoor cuts - pass and cut - flash cuts
5 min	Rebound & Blockout	3 on 3 or 4 on 4	Coach shoot ball - defence must block out & rebound without jumping - first team to 4 rebounds
4 min	Team Offence	5 on 0 Offence	Practice movement without defence. Emphasis - spacing - timing
8 min		4 on 4 / 5 on 5	Half or Full Court Practice team offence with defensive pressure
2 min	Fun Drill	Shooting Game or Relay	21 shooting game or full court dribble and shoot relay
	Cool Down, Stretch & Talk	Slow Jog, Stretching	Stretching and talk can be undertaken off the court if court time is a problem
Total 90 min			



The “Nitty-Gritty” of Coaching

Often coaching involves teaching new skills and organising athletes into drills, so that those skills may be practiced. The following offers some practical suggestions to help the coach.

Demonstrating Skills & Drills

Demonstrations of particular skills are more effective if they are:

- Suitable to the athletes skill level and stage of development
- Performed at normal or game speed
- Preceded by brief instruction, paying attention to main teaching points.
- Followed by immediate opportunity for the athlete to practice.
- Accompanied by praise and encouragement
- Followed by a relevant drill within which the particular skill is practiced.

When giving demonstrations coaches should follow a set routine, based on the following model.

Process

Suggestion

1. Gain attention

Use a [whistle](#), [clap](#) or [loud voice](#)

2. Name the skill

Brief description of skills “[We are going to practice a chest pass](#)” or give the name of the drill you are introducing.

3. Demonstrate

Brief demonstration highlighting key teaching points

4. Athletes have a go

Let athletes [have a go](#) and perform the skill.

5. Observe

The coach [observes and evaluates](#) the athletes performance

6. Instruct

Stop the drill. [Highlight strengths](#), reinforce [key teaching points](#).

7. Practice again

Allow further practice. Reinforce [key teaching points](#). Withdraw individuals for personalized instruction. “[Coach on the run](#)”. Don't stop the drill, reinforce while they practice.

Organising Athletes at Training

When organising athletes on the training court, coaches should be mindful of individual differences in talent, size and ability.

Daily drilling of fundamental skills needs to be varied, allowing the athletes the opportunity to practice:

- By themselves
- In groups
- As a team

How to Form Small Groups

Depending on the specific skill and associated drill being run, athletes can be divided into smaller groups (or individually) according to their:

1. Playing position
2. Height and general size
3. Playing experience
4. Skill level

These groupings attempt to cater for individual differences and allow the coach to have athletes matched-up evenly. Obviously drills involving the team will not require any re-grouping. When scrimmaging it may be necessary to balance the size and general skill level of the competing teams.

Whether the skill or drill to be run is done individually or in-groups, the coach will need to communicate the following information to the athletes:

WHAT	the skill/drill is - give each drill a name
WHERE	the drill is to be run
WHO	is to be involved in the drill?

Examples of Forming Groups During Training

Example 1 Individual Practice

“Each player needs a ball, form three lines behind the baseline. We are going to practice crossover dribbles down the court. Concentrate on keeping the head up. Use either hand!”

Example 2 Practice in pairs

“Pair up with a team-mate of similar size and position. Find a space on the court and practice chest passes. Concentrate on snapping the wrists .”

Example 3 Practice in groups of three

“1,2 and 3, each of you take two team-mates and go to a basket. Play 1 on 1 at the low post with the third man passing from the wing spot.” “Rotate positions once you have made two baskets.”

Example 4 Practice in groups of four

"I want four guards at one end of the court and four forwards at the other end. Split into pairs and use both sides of the basket. Guards practice shot fake and drives. Forwards practice shot fake and shot from the low post."

Example 5 Practice in groups of five

"The five that were last to run in can be the first group to run continuous 5 man weaves starting from that end of the court. Complete and make four baskets in a row and then the other five players take over."

Sometimes some athletes will not be able to train and this may mean that the coach cannot use the groups they had intended. A coach must be ready to make changes to group sizes where necessary. In situations such as these you either:

1. Change the drill to suit your numbers
2. Have two different drills running simultaneously
3. Have individual players step out of a drill and have them work on a specific area of weakness.

Moving from One Drill to the Next

Establish a practice rule where all players must hustle to the coach's side when they hear a whistle or the coach's voice. (Allocate penalties to slow movers.) Other than using the whistle, coaches may change from one drill to the next without stopping the entire squad. Here are some examples of how this may be achieved:

Combining Groups

Combining groups can be a good method of continuing training without too much reorganising. As indicated in the following example.

Assume you have three groups of three, each practicing a different skill eg. passing, dribbling and shooting. Combine the three passers and the three shooters. You now have six athletes who can now practice and possibly start a new drill. While the other three can continue their activity or start a new drill.

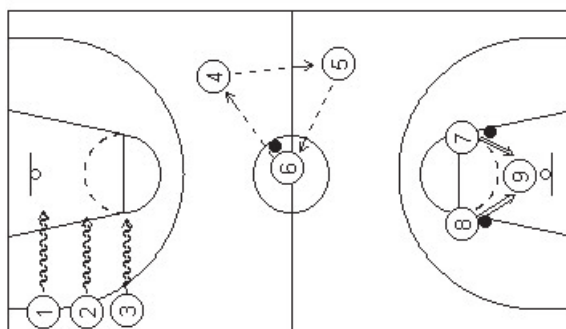

Re-arrange your Groups

Assume you have three groups each practicing a different skill e.g. Drive fake, drive and shoot, pass and cut and low post moves. Simply take one or two athletes from each group and swap them with one or two from the next group. There are still three groups practising the three skills above, but specific individuals have now moved onto a different skill to the one with which they started. Individuals may be withdrawn completely for specific attention.

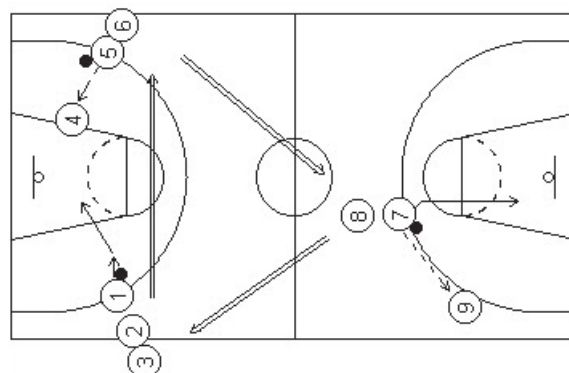

Move the Whole Group

Assume there are three or four groups each working on a different skill. Provided there are appropriate numbers in every group the coach may simply blow the whistle and have each group rotate on to the next drill. This is also referred to as **station work**.

Organising Drills

Two of the most common methods of organising a drill are known as:

- Corridor work
- Station work

Corridor work

The following diagram shows how the squad may be arranged and organised. Athletes are simply divided into three or four lines at each end of the court as shown. Each group is then instructed to stay within their corridor as defined by the coach. Each line may practice the same skill, such as dribbling, or they may practice a variety of skills, with each line completing a different task.

- For example:
- Line 1 Cross-over dribbles
 - Line 2 Reverse dribbles
 - Line 3 Behind the back dribbles
 - Line 4 Through the legs dribbles

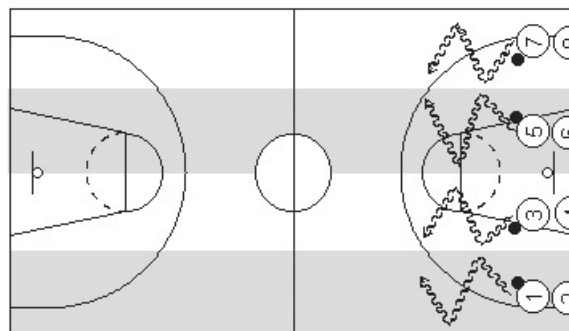

Activities that can be run using corridor work include:

- | | |
|-------------------------------------|--------------------------|
| 1. Running (Change Pace/ Direction) | 4. Dribbling (All Types) |
| 2. Stopping (Jump And Stride Stop) | 5. Passing (All Types) |
| 3. Pivoting (Forward And Reverse) | 6. Individual Defence |

Station work

With effective planning coaches can set up as many stations as they wish. Athletes simply move from one station to the next on the sound of a whistle or once time has run out. The coach should be active in correcting individual technique and giving individual instruction where required. To assist continuity, the coach may simply place a sheet of paper at each station detailing the skill to be practiced.

The routine and skills practiced using the corridor or station method can vary from one training to the next, according to individual and team needs. It is often preferable for organisational purposes to have at least two athletes at each station to ensure sufficient rest is allocated between each drill.

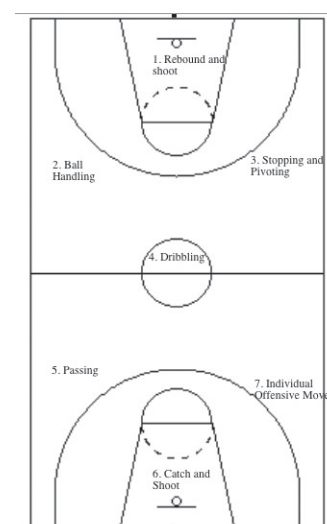

Skill training in groups

The type of skill training outlined in the previous section is unique in that the athlete without having a partner can practice all of the skills mentioned. Partners may be used if necessary.

Basketball is a team game. A certain amount of time at training must be devoted to working in groups of 2 or more. Certain skills of the game cannot, by definition, be practiced alone by the individual athlete.

Making Drills Competitive

Coaches will find that skill learning on its own may become tedious for the athlete regardless of the variety injected into the training session.

Additionally, athletes may tend to perform with a lack of intensity. Especially, for the very young athlete, the element of “fun” needs to be an integral part of training. The following are some suggestions that will add intensity and enjoyment to training sessions and drills. Be careful not to overdo the competitive element. Young players need to feel comfortable with a skill; otherwise technique may suffer at the expense of intensity.

Between drills

Have athletes hustle from one drill to the next and move into position quickly. Let them know at the first training session what you expect of them. Many coaches require the athletes' attention first, before the next drill, to give a demonstration, encourage performance or refine a few teaching points. The simplest, most effective way of moving athletes from one point on the court to another is on a whistle command.

Coaches may choose to have the last athlete into position do some form of penalty. Penalties can help improve in this area. This in itself then becomes competitive. If the squad is generally slow moving coaches may have all participants do penalties.

During drills

Team and individual competitiveness and intensity can be improved in the following ways:

- Against the clock, e.g. count the number of lay-ups, successfully completed in 30 seconds.
- Against each other, e.g. relay races involving dribbling down the court, shooting competitions,
- Against oneself, e.g. shooting from the foul line, record successful shots made out of total attempts.
- Circuit race, e.g. have athletes in pairs complete a circuit of drills combining a number of skills,
- Team against team scrimmage, e.g. first to score 5 points, award points to defence for steals etc. You may give penalties (push-ups) to the losers.

Evaluating Skill Performance

The evaluation of the athlete's skill performance involves the following:

1. Knowledge of correct technique
2. Observation of performance
3. Communicating the observations to the athlete.

Knowledge of correct technique maybe acquired through watching skilled athletes, reference to texts and videos and communication with other coaches. This knowledge will help to facilitate evaluation of how the skill was performed. Coaches should never rush into making assessments. Often you may need to observe the situation a number of times before making any judgements. It is often also helpful to observe the athletes from a number of different angles – behind them, in front of them and on the side.

When communicating an evaluation to the athlete, it should be done in a supportive manner. The coach or a skilled player may provide a demonstration of the skill and this should be accompanied with verbal reference to each of the correct aspects of technique. It is important to use the 'sandwich technique' when giving feedback. Praise the athlete, then give constructive correction, and finish with praise. For example, “Jane, your footwork was really good. Next time make sure you get lower by bending your knees. You are doing really well.”

The skilful coach will not highlight a player's errors but will offer alternative suggestions as to how that athlete may perform the skill correctly. Advice to the athlete will be put in terms of:

“Keep Your Head Up When Dribbling”

(Demonstration occurs)

rather than

“Don't Dribble the Ball with your Head Down!”

Finally coaches need to be aware that a successful outcome (eg. scoring a basket, making a pass, dribbling past an opponent) doesn't necessarily imply correct execution. Faulty technique will always be exposed against better opposition and coaches should emphasise correct execution.

Managing Efficient Training Sessions

Here are sixteen ideas to effectively manage a training session.

1. Be on time
2. Be appropriately attired
3. Have equipment ready
4. Have training planned
5. Have athletes move into action quickly
6. Make drills specific to long and short term goals
7. Alternate drills to maintain variety, intensity and concentration
8. Train at game pace
9. Alternate physically demanding drills with less intensive work
10. Have athletes move quickly from one drill to the next
11. No standing around
12. Introduce new skills when athletes are fresh
13. Provide brief, concise demonstrations
14. Have the athletes learn by doing
15. Be supportive, fair and firm
16. Show humour, finish training on a happy note

Coach - Referee Relations

Ever complained strongly about a referee's decision or ever seen a coach go absolutely crazy about a decision made by a referee? This section aims to investigate the roles and relationships between a coach and referee. It will attempt to help both coach and referee help each other in a quest towards coaching and refereeing a successful game of basketball.

Coaches and referees have quite separate roles and responsibilities in the conduct of a game of basketball. A coach's job is to teach athletes how to play and to make decisions relative to the game.

Probably the first thing to remember is that your players, and often spectators, will often act the way you do toward referees.

An official's job is to arbitrate and interpret the legality of playing situations as they arise, and generally facilitate the game flow.

While each role is quite distinct, it follows that neither coach nor referee should encroach on each other's duties. A coach should avoid interpreting and making public any comments about decisions arrived at by the referee. Nor should a referee make public their observations of coaches and their ability to coach.

Both coaches and referees should work to help each other, as both are striving towards providing a quality game for participants. While a coach teaches athletes to play well, the official should encourage them to play well through good officiating.

Often coaches can develop pre-conceived ideas about officials. This can be a dangerous attitude to adopt. Coaches should be realistic in appraisals of referees and not let a few "perceived" poor calls colour their total perception. Remember that referees, like players and coaches, will make mistakes but they do not deliberately make them.

The following list of suggestions can help beginner coaches develop good working relationships with officials.

Before the game

1. Have a competent knowledge of the rules
2. Make sure the score sheet is completed accurately
3. Get to know the officials, wish them a good game
4. Clarify any points of confusion prior to the game

During the game

1. Keep comments directed at your players
2. Avoid signs of frustration
3. Address the referee courteously
4. To query a decision use a time out and notify the score bench of your intention
5. Politely ask the referee for clarification of any rulings
6. If you have politely asked the referee a question, do not continue to argue if you disagree with their answer.

After the game

1. Shake hands with the opposing coach
2. Thank the referees and the score bench for the game
3. Leave the stadium on good terms with officials and opposition

It is important to note that one-day you are bound to get those same officials. It is vital to work with them not against them. Once the referee's whistle has blown it is highly unlikely they will change their decision. It is best to get on with the game.

The Legal Responsibilities of Coaching

The law is the method by which our society determines the rights of a citizen in a particular situation. It touches every aspect of life, and sport, including basketball, is no exception. As basketball becomes more professional, those involved will increasingly turn to the courts to protect their rights.

Sports people are often surprised that the law will involve itself in their area. The fact is, however, that the law is the means which society adopts for the protection of rights and the settlement of disputes.

So....

- Anyone who accepts a coaching position, whether purely voluntary or as a professional, has a legal responsibility to provide their athletes with the best of care. This means taking reasonable care to provide a safe environment.
- A coach can be found negligent if something they do (or failed to do) leads to an athlete suffering an injury that the court thinks was 'foreseeable'. For example, if there was a large puddle of water on the court, it is foreseeable that an athlete might slip on it and be injured.
- This standard of care is based on what are known about the prevention and care of injuries and other aspects of coaching. Coaches will be judged not by what they know, but what they should have known. Ignorance is no excuse in law. The coach must then act in accordance with that knowledge. Coaches owe it to their athletes to be competent in all aspects of coaching. They also have a duty to regularly update their coaching knowledge and to keep themselves informed of new developments. A court will compare what the coach did, or didn't do, with what the court thinks they should have done.
- Lawsuits have been brought against coaches for not teaching skills properly, failing to adequately supervise activities and for failing to carry out correct first aid procedures. Coaches have at least 10 important duties when carrying out their activities.

Ten important duties for any coach:

1. Provide a safe environment

Facilities and equipment must be safe for both the users and the others involved in the competition. For outdoor practice or games adverse weather conditions must also be taken into consideration. Coaches should check all equipment and the court before training.

2. Activities should be adequately planned

Impaired learning ability and injury may be the result of unplanned practice sessions. Using appropriate progressions in the teaching of new skills, especially potentially dangerous skills, is imperative. The drills a coach chooses to use must be suitable for the athletes they are coaching. For example, a drill that is suitable, and safe, for adults may not be suitable for young children.

3. Athletes must be evaluated for injury and incapacity

Young athletes with an injury or incapacity should not be expected to perform any potentially harmful activity. No athletes should ever be forced to take part in any activity that they do not wish to. Individual differences must be accounted for. Coaches should ask athletes before the start of training whether they have any injuries or feel unwell.

4. Young athletes should not be mismatched

Young athletes should be matched not only according to age, but also height, weight and maturity particularly in competitive drills where contact may occur. Skill levels and experience should also be considered.

5. Safe and proper equipment should be provided

Existing codes and standards for equipment should be kept in good order. Equipment should always be adequately repaired so that it is safe to use at all times.

6. Athletes must be warned of the inherent risks of the sport

The participants can only legally accept the inherent risks of any sport if they know, understand and appreciate those risks. In some situations, even such as warning may not be enough: for example, where people are involved in a school supervised activity.

It is prudent for athletes to wear mouthguards (as injuries to the face are common) and strap their ankles (or wear ankle braces) as ankle injuries are also common.

7. Activities must be closely supervised

Adequate supervision is necessary to ensure the practice and competitive environment is safe as possible.

8. Coaches should know first aid

Coaches should have a knowledge of basic emergency procedures and keep them up to date. They should take time to learn the following two procedures STOP (Stop, Talk, Observe, Prevent further injury) and RICER (Rest, Ice, Compression, Elevation) for the management of injuries.

9. Develop clear, written rules for training and general conduct

Many injuries are the result of misconduct in change rooms and training venues. Clear written rules should be developed for general conduct and behaviour in such situations.

10. Coaches should keep adequate records

Adequate records are useful aids to planning and are essential in all cases of injury. Notes should be kept on all athletes, including relevant general and medical information and progress reports. Accident reports (not diagnosis) should be made as soon as possible after each injury occurs. Coaches should also keep a note that they inspected equipment and the court before training. This could be written onto the training plan.

The above ten points will help to reduce the chances of a successful claim of negligence. These points will also ensure that the coach is not only reducing this risk but is also ensuring they are following good coaching practices.

Coaches can further protect themselves by taking out professional indemnity insurance and ensuring that all their athletes are covered by injury insurance. In some States coaches and players automatically are covered by insurance through the registration process. Check with your State Association if you are unclear.

CHAPTER 4: BASKETBALL FOR PEOPLE WITH A DISABILITY

The following information is copyright of the Australian Sports Commission and has been reproduced in this publication with their permission.

Role of the coach

Coaching athletes with a disability is no different to coaching athletes without disabilities. There are very few disabilities or medical conditions, which completely preclude participation in sport. Athletes with a disability play sport for the same reasons as everybody. They want to improve fitness, develop new skills, increase social contacts and to have the chance to achieve and receive recognition.

If coaching athletes with a disability is no different then, why is there a complete Chapter of this manual devoted to the inclusion of athletes with a disability? It is because the issue of inclusion is what needs to be addressed and understood – not the issue of coaching. If a coach has an inclusive approach to what they do then they will be able to coach athletes with a disability.

Developing an inclusive philosophy

Being inclusive as a coach is a fundamental requirement of being a good coach. Inclusion is not something only coaches of athletes with a disability do and it does not mean that coaches need 'special' skills or knowledge to coach athletes with a disability. The basic skills of good coaching, of organising, observing, analysing, communicating and improving performance, when applied with an inclusive philosophy, will ensure that athletes with disabilities are part and parcel of a coaches everyday life. So what exactly is an inclusive philosophy?

Social and medical models of disability

Traditionally, the problems of inclusion have been borne out of a preoccupation with impairment. People with a disability have been defined in terms of their impairment or condition. The fact a person uses a wheelchair or has vision impairment, for example, would dominate the thinking of a coach. This medical model approach reinforces many of the negative stereotypes of disability and perpetuates the myth that to coach a person with a disability you need a medical background or, at least, some form of specialist training.

Thankfully, times have changed and increasingly sport is recognising that the presence of impairment is only one factor to be considered when including people with a disability. For inclusion to work it is far more important to consider:

- coaching skills used,
- rules and regulations you adopt,
- environments in which you coach and
- equipment that you coach with.

This social model approach to inclusion can be very empowering for a coach as he or she is able to adapt and modify aspects of their coaching and create an environment that allows more people with a disability to take part. Clearly, under this model, the onus of inclusion rests with the coach and not with the fact that an athlete may have a particular impairment. Adopting a social model approach to coaching does not mean that you do not need to know about particular impairments or that medical information is not sometimes important. It simply provides a context for inclusion to work.

Provided the coach is prepared to accept each participant as an individual, coaching an athlete with a disability is not a difficult task. Every athlete is unique. Effective coaches adjust to accommodate individuals. Adopting an inclusive (social model) philosophy to your coaching will benefit you and your athletes, regardless of whether they have a disability or not.



Planning to include

The importance of planning cannot be overstated. The factors that effect yearly plans apply equally to the coach of an athlete with a disability. Inclusion works best when it is planned for. As you prepare your coaching program and examine what, if anything, you may need to adapt and modify, consider specifically:

- talking to the athlete to understand their specific needs
- talking to parents, carers and significant others to further help understand specific needs
- talking to your coaching peers, particularly if they coach athletes with disabilities
- finding information about the impairment that may help you understand some general considerations relevant to your sport
- the ability of the athlete to perform the skills and movements of a particular sport or activity. In other words, what or how the athlete can,
 - see (predominantly relevant to athletes with vision impairment)
 - hear (predominantly relevant to athletes who are deaf or hearing impaired)
 - move (predominantly relevant to athletes with a physical disability)
 - learn, recall or reproduce skills (predominantly relevant to athletes with an intellectual disability)
 - perform tasks and activities (relevant to all athletes).

Teaching sports skills & games

Athletes with a disability compete from club to international level in a wide range of sports. Many Australian individuals and teams are among the world's best and Australia has been very successful at recent Paralympics and other international events.

While there are some considerations concerning rules, equipment and sometimes technique, coaches do not in general need to treat athletes with a disability differently from any of their athletes. A coach can ensure their approach is inclusive by applying something called the TREE principle. TREE stands for:

Teaching / coaching style

Rules and regulations

Environments

Equipment

In the application of Game Sense the coach can use TREE as a practical tool and a mental map to help them adapt and modify game situations to be more inclusive of people with a disability. Through

careful observation a coach can highlight problems that players are having and how they go about addressing them. Where people with a disability are included into the game the observing/questioning role of the coach is paramount to find the best possible inclusive situation. This is where the coach can apply the TREE principle.

Consider how the TREE principle can help:

Situation:

You are a coach of a basketball squad that has one player with an intellectual disability and one player with a vision impairment. You have set up a Game Sense practice session involving all players. The session requires two players to retain possession from a third player without the third player intercepting or gaining possession of the ball. A simple 5 minute defence/possession activity. As you start the session you notice that the player with a vision impairment keeps dropping the ball and, as the single defensive player, cannot get close to touching or retrieving the ball. Also, the player with an intellectual disability seems a bit confused and 'disturbed' by all the activity.

Observation and questioning:

In applying the TREE principle the coach can ask the following questions. These may be directed at the whole group, at the smaller individual three person groups or even to individuals as the coach sees fit:

"Is the game too fast? What can we do to slow it down?" (Rules)

"What can we do to give [the person with vision impairment] the best possible chance of catching the ball?" (Equipment and Environments)

"How can we minimise distractions for this activity?" (Environments)

"What is the best position for players to stand?" (Environments)

In response to these questions some adaptations to the activity may be suggested that will help inclusion. These could include using bounce passing only to slow the game down and provide the person with a vision impairment an auditory cue. They may include using lighter, brighter or slower (partially deflated) balls or even changing the lighting of the setting to provide better contrast. It may mean changing the orientation of particular groups, for example, the group with the person with an intellectual disability conducts the activity in a more closed environment (in the corner of a room facing away from the group). This would help minimise distractions.

There are some general considerations for a coach that are in addition to many of the better coaching strategies outlined elsewhere in this manual. These are deliberately broad to give you an idea of the types of strategies that can be useful in coaching athletes with disabilities.

Managing

- Remember not lean on or touch a person's wheelchair without their consent. The wheelchair forms part of the user's personal space.
- Try not assume that using a wheelchair is, in itself, a tragedy. It is a means of freedom that allows the user to move about independently.

- Familiarise the athlete with vision impairment with obstacles in the area both at practice and at competition venues;
- Use the buddy system at practice or during a competition
- Be conversant with different rules. For example, wheelchair basketball has some rule variations
- Familiarise yourself with classification guidelines for sports that use classification guidelines for competition purposes;
- Ensure the venue has wheelchair access and that there are suitable facilities available
- Temperature, body position, type of movement, emotions and fatigue will all influence muscle tone for athletes with cerebral palsy. Discuss with the athlete, parents and doctor the best ways to minimise inappropriate muscle reflexes and tone.

Teaching

- Correct style manually, but do not push, prod or grab the person unexpectedly.
- Demonstrate all techniques individually, if necessary breaking down the movements into component parts. Let the athlete feel the coach perform a particular movement.
- For athletes with an intellectual disability avoid using abstract models, such as blackboard diagrams, when introducing skills. Teach new skills by showing so that the athlete has something to copy.
- Keep practice time on specific activities short to avoid concentration loss and boredom.
- Break skills into small teaching components, ensuring that each part is learned fully before progressing.
- Review and repeat skills and drills in different ways. Use drills that do not require elaborate decision-making or those, which rely heavily on literacy or numeracy skills for those athletes that have difficulties in this area.
- If necessary, move the individual through a desired motion when teaching new skills.
- Identify and practise safe methods for landing and spreading weight loads for athletes with lower leg amputation.
- Use varied drills and fitness activities to avoid overuse injuries of the upper body for wheelchair users.
- Ensure adequate fluid intake and body cooling in hot conditions. Athletes with spinal injuries have a decreased ability to regulate body temperature.
- Keep a log of time and distance rather than heart rates to monitor training improvements. Heart rates may not increase with exercise intensity for athletes with spinal cord injuries in the neck area.
- Warm-up, stretching and warm-down activities are essential for athletes with cerebral palsy. However, avoid sudden or ballistic stretching for athletes with spasticity as these may trigger a strong muscle contraction (stretch reflex).
- Short practice sessions provide better learning environments than one long practice session. Many athletes with cerebral palsy have short concentration spans and a high degree of muscle tone.

Coaching communication

- If a conversation lasts more than a few minutes, consider sitting down or kneeling to get yourself on the same level as the wheelchair user.
- It is okay to use expressions like 'running along'. It is likely that the wheelchair user expresses things the same way.
- For athletes that are deaf or hard of hearing, secure the athlete's attention before talking to them. Consider using a tactile clue, such as a wave, to gain attention;
- Provide written details of activities such as practice times, venues and equipment and uniform requirements;
- Develop a few basic signs for key instructions and questions;
- Position the athlete so he/she can observe the speaker's lips and hands when demonstrating techniques;
- Identify yourself and introduce the athlete with a vision impairment to others present;
- Always tell them when you have finished the conversation and are leaving the room/field;
- Be articulate and imaginative in the description of technique and the correction of errors;
- Give constant feedback of the progress of an activity or game which may be naturally observed by people with normal vision;
- Audible signals may be necessary to ascertain direction or distance.
- Keep instructions short, sequential and concrete. Use simple imagery to get the message across and be prepared to repeat key instructions frequently.
- Be specific in feedback. Acknowledgments must be spontaneous and immediate for some athletes with an intellectual disability
- Explain skills and give instructions in clear and simple terms. Use questioning techniques to ensure athletes have understood.
- Make sure all athletes are positioned for optimal viewing or hearing. This generally requires the coach to be being face on, within close range and in good light.
- Avoid background noise.
- Speak naturally and clearly. Hand gestures and facial expressions may make the message clearer.
- Speak directly to the athlete, not through a third person.
- Keep instructions brief and concise and present them in an interesting manner.
- Look for non-verbal cues from the athlete, such as posture, facial expressions and gestures, to check if the instruction has been understood.
- Check that the athlete has understood the instructions.

As with all athletes, coaches should:

- assess individual strength and weaknesses;
- set challenging and realistic goals;
- communicate efficiently;
- provide specific constructive feedback.

Coaches do not need to protect athletes with a disability from failure, give unearned praise or lower their expectations and standards for behaviour. Athletes with a disability are no more 'courageous' than any other athlete who works hard to achieve a goal.

In turn, an athlete with a disability must accept the risks, challenges, discipline, repetition and frustration, which are part of being a competitive athlete.

It is not essential to acquire extensive, detailed knowledge of causes, incidence levels, pathology, medical terms and the like to coach an athlete with a disability. The coach should check the health status of all athletes (whether they have a disability or not) and once it has been established that no medical or health related conditions exist, it is more important to spend time with the individual to assess their needs and ability.

The most effective coaches are those with sports specific knowledge and this is particularly important in coaching athletes with a disability. This knowledge is essential in order to know how to break skills into component parts and how to match each of these components with the athlete's ability level.

Basketball for Players with an Intellectual Disability

Technical and Rule Variations

There are absolutely no variations in the technical area or in the rules for basketball as they relate to players with an intellectual disability. Coaches stress that the rules of the game should be monitored by referees as stringently for players with an intellectual disability as they are for any players. Allowances should not be made because of the player's perceived disability. But as with any beginner, consideration will need to be given to players who are not familiar with the skills required for the game.

Skills Required

Players with an intellectual disability have the same physical characteristics and abilities as able-bodied players. Consequently, the skills required in basketball for players with an intellectual disability are exactly the same as those required by able-bodied players. Coaches can apply their specific knowledge in the same way they would for able-bodied players.

Tips for Coaching

Coaching basketballers with an intellectual disability is not a difficult task if the coach is able to accept each participant as an individual, and that it may take some players longer to acquire the skills to play the game. As with coaching all athletes, coaches need to:

- make an assessment of individual strengths and weaknesses
- set realistic and challenging goals
- communicate clearly
- provide positive feedback

The following specific considerations are relevant to coaching players with an intellectual disability:

- Make all sessions enjoyable for participants
- Keep language simple, brief and clear
- Do not make allowances for players with an intellectual disability – encourage them to meet the requirements of the sport to the best of their ability
- Be patient, tolerant, consistent and tactful
- Sequence learning tasks – if necessary, complex skills may need to be broken down into steps or stages
- Develop an understanding of the rules in accordance with an individual's ability and skill level
- Refer to players and select the activities they are to perform in accordance with their chronological age
- Encourage athletes and officials to communicate in age-appropriate and sports specific terminology
- Provide sports specific reinforcement
- Adjust the training loads and requirements of beginning players (bearing in mind that the physical fitness and basic motor skills of people with an intellectual disability are generally poorer than their able-bodied peers due primarily to a lack of opportunity to participate in physical activity programs rather than any physiological factors).

Wheelchair Basketball

The origins of the game of wheelchair basketball date back to the 1940s. Initially the game was developed as a rehabilitative activity for personnel from the armed forces who had been immobilised by war injuries. From these origins, the game has developed into a highly competitive sport recognised around the globe.

It should be noted that, although the emphasis in wheelchair basketball is on providing competition for people with a disability, there is scope for able-bodied players to compete in the game at the local level.

Technical Variations

Generally, wheelchair basketball retains the skills of the able-bodied game. There are however, some skills specific to wheelchair basketball, to which a coach with basketball knowledge must be able to adapt. These adaptations can be placed into three categories – offensive, defensive and rebounding.

Offensive Adaptation

Picking up ball up – In situation where the ball becomes loose, wheelchair basketballers are able to utilise their chair to recover the ball. The ball can be scooped from the floor with one hand using a handrim from one of the chairs wheels to assist. Using two arms for the pick up is difficult, and is some cases impossible, for players who have a high level of spinal cord injury.

Dribbling – When moving the ball around the court (other than in passing situations) a player in a wheelchair must not push the chair more than twice without bouncing the ball. To push the chair more than twice without a bounce constitutes a violation similar to a travel in the able-bodied game. When not bouncing the ball, the player may rest the ball in the lap. In fast break situations (development of skills in this area should be greatly encouraged by coaches), the dribble becomes an upward and forward tap of the ball to ensure the player in possession does not lose control.

Shooting – Shooting fundamentals such as high release and 'lock and snap' equally apply in wheelchair basketball. Given that shooting the ball in able-bodied basketball is a skill requiring involvement from most of the body's muscle groups (particularly the legs), shooting and laying-up the ball from a wheelchair requires a greater component of strength from the upper body (ie chest, shoulders and arms) to compensate for the limited involvement of leg muscles in the action.

Passing – No real adaptations are required when passing the ball in wheelchair basketball. Coaches should encourage players to develop a full range of passes (i.e. chest pass, baseball pass, push pass, overhead pass or bounce pass) using either or both hands. Again, greater strength may be required from players in wheelchairs to compensate for the lack of leg drive in passing situations.

Defensive Adaptations

Movement – As lateral movement in a wheelchair is limited, coaches must stress that defensive players maintain flat triangle positioning as much as possible. Movement is initially slower and more cumbersome in a wheelchair, thus a greater emphasis must be placed on maximising a position of advantage and denying space to the offensive player in possession.

Rebounding

Blockout – As in the able-bodied game, positioning in rebound situations (either offensive or defensive) is extremely important for wheelchair basketball players. It takes on added significance in wheelchair basketball as there is generally a lower percentage conversion rate of shots compared with the able-bodied game. Rebounding ability and the denial of position to an opponent can win games.

Rule Variations

The basic rule differences between wheelchair basketball and the able-bodied game are as follows:

Dribbling – as described in the technical variations, one bounce of the ball for every two pushes of the chair.

Fouls – generally the same as the able-bodied game, with some additional technical stipulations relating to charging, holding and interfering with an opponent's chair.

Lifting – Players are not permitted to lift themselves out of the wheelchair to gain an advantage over an opponent. Additionally, players are not permitted to take their feet off the foot rests to gain an advantage.

Classification – Players are provided with a classification according to their functional ability. Player classifications are determined by a classification committee and have point values from 1.0 to 4.5 according to functional capacity with 1.0 being those players with lower functional capacity. This is related to their physical function not their skill level.

Wheelchair Basketball Classification Points System

- | | |
|-----|--|
| 1 | No lower limb and little or no trunk movement. Rebound overhead with one hand. |
| 2 | No lower limb but have partial trunk control in a forward direction. Must rely on hand-grip to remain stable in collisions |
| 3 | Some limb movement and more control of their trunk. Can rebound overhead with two hands. |
| 4 | Normal trunk movement but some reduced lower limb function. Unable to lean to both sides with full control. |
| 4.5 | Minimal lower limb dysfunction or single below knee amputation. Normal trunk movements in all directions. |

At no time in a game is a team permitted to have players participating whose total point values exceed 14 points.

Skills Required

Many coaches who have been asked to coach players in wheelchair have tried to resolve the question of “what can the player do?” in accordance with stereotyped images of what they perceive a wheelchair athlete to do. Generally, the best advice for coaches wishing to know the capabilities of a team member is to “ask the player”.

Additionally the ability to adapt basketball and coaching knowledge to suit the minor technical and rule differences inherent in wheelchair basketball is highly desirable.

Tips for Coaching

As with coaching all players, coaches of wheelchair basketballers need to:

- Assess the capabilities of the player. Don't focus on what the player cannot do, focus instead on what they can do and have the potential to do.
- Try performing some of the skills associated with basketball from a sitting position (eg passing a ball while sitting down).
- Try to borrow a wheelchair and experience moving around in a competition or training session
- Try to get involved in a wheelchair basketball scrimmage to get a feel for what is required of players in a game situation.

Coaching basketballers with a disability is not a difficult task if the coach is able to accept each player as an individual. As with coaching any athletes, coaches of basketballers with a disability need to concentrate on assessment of strengths and weaknesses, realistic and challenging goal setting, clear communication and providing positive feedback.

CHAPTER 5: SPORTS SCIENCE

Sports science is becoming increasingly important, particularly at elite levels of our sport. As a coach starting out in the sport of basketball it is important to have some basic knowledge of sports science.

The following section is aimed as a basic introduction into sport as a science and looks to identify basic areas in the following disciplines:

- Components of Fitness
- Principles of Training
- Fitness Training and Stretching
- Sports Safety
- Basketball Injuries and Treatment
- Sports Psychology

This section is merely the tip of the ice berg in relation to sports science. Further information in relation to these areas can be located through various state and national sporting bodies. In addition, a detailed reference is given to these areas in the Level 2 and 3 basketball coaches courses.

Components of Fitness

The sport of basketball has evolved to a stage where the various areas of fitness become essential for an athlete looking to go further in the sport. Physical conditioning aims to enhance both the energy systems and muscular systems of the body. Improvements in these areas will not only improve fitness levels but will enhance skill execution.

Basketball players expend large amounts of energy. If their bodies are not trained to cope with this fatigue, poor performance may result. As a coach it is important to be able to identify the essential areas of fitness that directly relate to basketball. The following identifies the five components of fitness that are relevant to basketball:

- Strength
- Power
- Speed
- Endurance
- Flexibility

Strength

Strength is the ability of the body to apply force against resistance. Strength is an advantage for a basketball player when making heavy contact with an opponent. For example a post player playing one on one inside. Strength would provide the athlete with the ability to hold their ground and not be pushed around.

Developing Strength - To improve this component a supervised weight-training program is recommended. This program would involve heavy loads with limited repetitions. Exercises against own body weight (such as push ups, sit ups, dips and squats), isometric and isotonic exercises also help to improve this area.

Power

Power is also referred to as explosive strength. This is the result of a combination of two fitness components, strength and speed.

Developing Power - To improve this component a supervised weight training program focusing on medium loads performed explosively would be beneficial. Circuit training, jumping training and exercises involving overload would also assist in improving power.

Speed

Speed is the maximum velocity of muscle contraction that the body can generate. Acceleration is advantageous in a fast and flowing game like basketball. Clearly a player with speed is more difficult to manage whether they are on defence or offence. Speed can also be very useful in relation to fast breaks and transition basketball in general.

Developing Speed - Sprinting programs are extremely useful in developing this area. In addition-reaction type drills may assist.

Endurance

Endurance is the maximum work muscles can perform in repeated contractions. There are two types of endurance General and Specific. General endurance is determined by the ability to resist fatigue under conditions where oxygen intake and consumption are kept at a steady rate. Specific endurance is the ability to resist fatigue under conditions where lactic acid is accumulated in the muscles. Basketball is a game where fatigue can set in quickly. Players require sufficient rest.

Developing Endurance

General Endurance: Runs over long distances, cross country, or Fartlek training.

Any exercise where oxygen and consumption stay at a steady rate.

Specific Endurance: High-speed activities with relatively short recoveries.

Flexibility

Flexibility is the range of movements in or around a joint or a series of joints. It is essential in basketball due to the range of activities the athlete has to perform.

Developing Flexibility - Stretching exercises, repeated regularly, are the best method of improving flexibility.

Principles of Training

Once you have gained a clear understanding of the physical components required for basketball, it is then important to be able to apply this and develop a program to promote the appropriate conditioning required for basketball.

The following six principles should be used when designing a training program for conditioning your athletes.

1. Specificity
2. Progression
3. Individuality
4. Variety
5. Overload
6. Reversibility

1. Specificity

Different physical exercises have specific conditioning effects. It is vital to make each exercise as specific to basketball as possible. It is also important to make a program as specific as possible to the needs of the athlete. Each athlete is different so it is important to consider this and to cater for the needs of individuals.

2. Progression

Progression is the principle that conditioning must start at an exercise intensity which the body can handle. Consideration should be given for recovery time prior to increasing the athlete's workload. If this principle is not adhered to and athletes are forced to progress rapidly without sufficient rest, injury or illness may result. Close monitoring of athletes will help with this process. Ask the athlete; they are the best judges of their own body.

3. Individuality

It is important that every training program be specific to meet the demands of each individual. Every athlete is different in physical make-up. Some athletes may require work in certain areas such as strength, therefore coaches should attempt to cater for each individual's needs. Each individual is the best person to monitor their training program. It is important to educate athletes so they can monitor their own bodies, particularly in the following areas:

1. Intensity and duration of work.
2. Areas of improvement.

4. Variety

Any training program must contain variety. Without variety training may become boring and tedious. Keeping training varied will help keep athletes motivated.

Strategy's to achieve variety include:

1. Change the type of activity;
2. Changing between competitive and non-competitive training regimes;
3. Using a variety of drills and training methods.

5. Overload

For rapid improvement in any training program, overload is essential. For athletes to improve they must increase the previous demands of their initial training program.

For example:

1. For athletes to improve their strength they must attempt to lift more weight than previously lifted. This should be done carefully and be closely monitored. Small gains are always better than injury.
2. For athletes to improve their speed they may need to gradually increase the amount of repetitions of sprints they complete.

6. Reversibility

Any gains an athlete may make in a fitness program may be reversed if the athlete decides to cease activity. This may also occur where the training load is reduced. This may occur during the competition phase of the season. Here athletes may have worked hard in the pre-season phase to improve their fitness and then neglect to maintain this during competition. The result may mean a decline in performance throughout the season.

Pre season training

This is the period building up to a season where athletes should be working as hard as possible to improve their fitness levels. During this period athletes should work to improve any areas of weakness such as strength, flexibility, agility, power, speed, endurance. A focus should be given to these areas to ensure the athlete is fully prepared for the upcoming season.

As a coach you can assist the athlete in identifying their areas of weakness.

Competition phase

The object of this phase is to produce the optimal performances of the year. The main competition phase should not be shorter than 6 weeks in order to recover and prepare for the identified seasonal climax. During the early season competition phase, skill development receives its final polish and is evaluated in competition situations. During this period of the season, the training volume is reduced but intensity remains relatively high.

Fitness Training and Stretching

Fitness training forms a minor part of the requirements of a young basketball player. The coach should be concentrating on teaching the player the fundamentals of the game and developing professional habits, which will allow the player to play the game to their true ability. The purpose of any fitness training at a young age should be to develop good training habits and to start building a fitness base that will allow the player to undertake heavier training loads in future years without the risk of injury.

Aims of training for young athletes

Training programs for young players need to be aimed at developing all-round athletic ability. This is not the time to have players doing very specialised training. The aim of any fitness work at this level is to work the whole body and to use a number of different methods to do this.

Planning physical training

In order to avoid over-training, young player's physical fitness training should only be carried out for short periods of time. Usually four to six weeks is enough time to make some improvements. The fitness component of training should then be taken out of the program and development should become the exclusive area of emphasis. Another block of fitness work can be used later in the year. Most young players are involved in another sport, which gives supplementary fitness training anyway.

A gradual increase in training load over a number of years leads to players being able to achieve things that they would not have believed possible and with less risk of injury than the approach of saying, "You shouldn't be doing any of this heavy training until you are 15 or 16 years old". Therefore, while saying that young players should not be expected to do too much fitness training, those who have started some form of training at a young age will be able to achieve higher levels in the longer term.

By using a variety of full court drills, a coach can work on improving the fitness of athletes at the same time as their basketball skills.

Warm Up and Cool Down

The purpose of a warm-up is to prepare a player for the game or training session ahead and to help prevent injuries. Players must get into the habit of warming-up properly before every training session. Warm-down is just as important as a warm-up. This is also the part of training most neglected by coaches and players alike. By doing a correct warm-down after training, and especially games, the degree of stiffness and soreness in muscles can be decreased. This is also the time to work on improving flexibility - not in the warm-up.

Warm-up

The most important point to remember about a warm-up is that its purpose is to get the body warm. Some coaches spend too much time on stretching and consequently the players are still cold when they come to start their first training drill. The warm-down is the time to do most of the stretching. A good warm-up consists of three major parts:

- **General warm-up**

This is some light exercise, usually jogging or skipping, to start to get the muscles warm. This needs to be done before the stretching can start. Muscles need to be warm before they are stretched.

- **Stretching**

This should take no more than 10 minutes in a warm-up. Stretching should concentrate on the major muscles to be used in training.

- **Specific warm-up**

This could be lay-ups or a passing drill, which goes for 3-4 minutes. The aim is to start out gently and to build up to game tempo.

Warm-down

Warming-down is the reverse process to warming-up. Players go through a gentle exercise warm-down followed by stretching. Warm-down consists of:

- **Cool-down exercise**

Gentle jogging or similar exercise is all that is required here. This only needs to last for a couple of minutes.

- **Stretching**

Now is the time to make sure that players stretch properly. All body parts that have been trained need to be stretched well. Stretches should be held for up to 30 seconds in a warm-down. This will help improve flexibility.

The most commonly used type of stretching in sport is called static stretching. Static stretching involves taking the muscle to a point where tension is felt and held there for between 10 and 30 seconds.

How to stretch:

1. Breathe normally - do **not** hold your breath.
2. Stretch **warm** muscles only, to a light sweat.
3. Take each stretch to where you **feel** tension but **not** to where the muscles shake.
4. Hold each stretch for at least 10 seconds.
5. **Do not bounce.**
6. Try to relax other body parts while you stretch.

Stretches for Basketball

The following is an outline of the stretching exercises that will be useful for basketball. Each stretch should be done before and after training:

Calf

- back toe points forward and leg straight
- push heel to floor
- move chest to the wall, weight forward



Achilles

- squat position, both hands on floor
- one foot slightly forward and flat on the floor
- lean knee beyond the foot



Thigh

- hold ankle not foot keep space between hip and ankle push hip forward



Hamstrings

- tuck foot into thigh bend from hips and keep chest up stretch with both hands



Groin

- hold ankles not feet
- elbows press against knees
- lean forward



Gluteals

- keep head and shoulders on floor
- pull ankle, not foot, towards opposite shoulder
- adjust angle of leg to suit



Lower back

- opposite elbow to outside of knee and press against knee
- hold opposite hip with hand and pull
- look over opposite shoulder



Mid back

- hold opposite elbows underneath legs
- relax shoulders - pull shoulder blades apart



Front shoulder

- side on to wall
- bent elbow
- turn away from hand



Shoulder

- one hand behind same shoulder and other behind back
- grasp towel and creep fingers of hands towards each other



General Conditioning Circuit for Basketball

During the phase where young players are training, one of the best forms of training, to develop a combination of aerobic fitness and some muscular endurance, is circuit training. This involves doing a number of exercises in a continuous manner with only short rests between each exercise. When using circuit training for young players, it is important that the loads being used are kept very light so that the players can do a high number of repetitions of each exercise. For example, it may be more appropriate for some players to do a light dumbbell bench-press exercise than to try to struggle through push-ups and only be able to do four or five.

Circuit training guidelines

- Use exercises where the players will be able to do 15-20 repetitions comfortably.
- The circuit should have between eight and fifteen exercises depending on the time allowed at each station.
- Avoid too many exercises in the circuit, which involve jumping and bounding.
- The total time for the circuit session should be no more than 20 minutes.

Sample exercise circuit

This circuit is a simple exercise circuit, which can be done at home or around a basketball court. Some of the exercises like skipping can be done for a set time rather than a set number of repetitions. The intensity of the circuit can be changed in a number of ways. The first is to increase the number of repetitions or time that each exercise is performed. The second is to add weight or extra resistance to each exercise. Finally, the circuit can be made harder by completing more than once. The difficulty should only be increased once a player is handling the load comfortably and has been doing so for some time.

1. Modified push-ups or bench press
2. Shuffle run
3. Sit-ups or partial sit-ups
4. Chest pass against wall
5. Dumbbell military press
6. Skipping
7. Partial chin-ups with feet supported
8. Sit-ups
9. Defensive slide drills
10. Dribbling on the spot shuffle

Sports Safety

Every coach, no matter what sport they may be involved in, should work towards creating a safe environment for his or her athletes. Basketball is a sport, which can often involve physical contact and strong vigorous activity. With this in mind it is inevitable that collision will occur, which provides for the possibility of injury.

As a coach it is important to not only educate athletes but to use appropriate training methods and techniques to decrease or limit the chance of injury.

In the following section we will look at injury prevention techniques and how to treat common basketball injuries.

Every coach should have a basic first aid kit with them at every training.

Injury Prevention Techniques

Educate Your Athletes

A major part of injury prevention for coaches is education. It is important to teach players how to monitor their own bodies, to know how far they can push themselves, to speak up when injured and how to manage any subsequent rehabilitation. As a coach there are a variety of areas that a coach can assist in educating athletes. These include:

- **Equipment, Apparel and Facilities**

The first responsibility for any coach is to ensure that your athletes are appropriately attired. Equipment and the facility must also be free from obstructions and potential dangers.

Equipment

- Players should wear appropriate basketball shoes
- Mouth guards are recommended to protect teeth
- Ankle braces, and strapping using tape help to protect the most commonly injured areas.

Facility

- Must be clear from obstructions
- Check that there are no water or slippery substances on court surfaces

- **Rules and Discipline**

The rules of the game have been developed to provide a safe playing environment. Players must have a good understanding of the rules and observe them at practice and in their games. Coaches may also change some basketball rules, eg do not allow dribbling, to cater for younger athletes.

A coach must develop training rules to ensure a disciplined and safe environment at practice sessions.

Warm Up and Cool Down

Before commencing any physical activity a coach should provide adequate time for Warm Up and Cool Down.

- **Warm Up**

A warm up and stretch is used for the following purposes.

- Increase breathing rate, heart rate and muscle temperature ready to perform exercise
- Reduce risk of injury
- Prepare athlete mentally for the game or practice session.

- **Cool Down**

A cool down is designed to minimise muscle soreness following exercise. Alleviating this discomfort also helps to prepare the athletes for their next upcoming session and further helps to reduce injury during their next session.

Fitness

Fitness levels of athletes vary considerably as each athlete has a different and specific physical make up. As a coach it is important to understand this and be specific to the demands of each athlete. It is important to take this into consideration when organising an exercise program. Clearly each program should be varied to cater for the needs of each individual.

Environmental Conditions

The major environmental factor players in Australia must contend with is heat. Heat stroke and heat exhaustion are common experiences in the hotter climates and in summer. Heat stroke and heat exhaustion can be extremely dangerous and in some cases fatal. As a coach it is essential for coaches to monitor athletes and ensure that they are properly hydrated. Controlling body temperature is vital. An increase in the body's core temperature can significantly reduce performance levels, and endanger the health of the athlete

Fluid Replacement

When the body exercise it loses fluid. This fluid must in some way be replaced. Drinking water before, during or after can help to prevent dehydration. It is recommended that the athlete should consume at least one litre of water one hour prior to competition. This will mean the body is carrying excess water and when fluid is lost will simply be a matter of topping up. This fluid should be cool.

Balanced Groups

It is important to keep competitive drills and competitions at training balanced to reduce injuries, particularly in those that involve more physical activity.

Consideration should be given to age, size strength and skill of the players.

Basketball Injuries and Treatment

Even though basketball is a non-contact sport, contact injuries are inevitable. These may come from another player, the floor, and obstructions outside the court or the backboard. The other common form of injury is overuse injury. These injuries are chronic, slowly developing problems of tissue breakdown that occur in response to the stresses of the game.

Common basketball injuries

Ankle

Ankle ligament sprains are the most common injury in basketball. Usually they are due to the ankle rolling in, or inverting, causing stress to the ankle.

More serious ankle sprains will involve damage to the deltoid ligament at the rear or posterior aspect of the joint, and the talus bone. Some avulsion fractures are common and more serious fractures to the tibia, fibula or talus may result.

Ankle taping and the use of ankle braces, along with high cut boots, will help to reduce the incidence and severity of these sprains.

Foot

Frequent running and jumping on a firm surface over a long season may result in foot injuries. A common problem associated with the foot include blisters and calluses. More serious injuries include joint sprains, stress fractures, plantar fasciitis and apophysitis (inflammation in a growth plate).

Leg

The most common injuries associated with the leg include muscle strains and haematomas (or carked leg). Overuse injuries such as stress fractures, Achilles tendonitis, and shin splints are occasionally found.

Back

Back injuries are common to basketball due to the constant pounding on a hard surface and the contact with other players that the back has to endure. Often common problems are associated with the lower back. Flexibility exercises and the strengthening of stomach muscles can assist in the prevention of back problems.

Head

Concussion, nasal fractures, facial lacerations and small depression fractures to the face are common injuries to the head. Often this is the result of an elbow or a clash of heads.

Knee

Knee injuries can often be devastating to a player. Serious knee injuries involve the tearing of both or either of the anterior and posterior cruciate ligaments and the medial and lateral collateral ligaments. This is often the result of a player landing awkwardly or heavy contact with another player. These types of injuries often result in knee reconstructions with the player having to go through extensive rehabilitation.

Overuse injuries are also evident with the knee. The extensor mechanism breakdown is the most common. This name covers a range of conditions known as Patellar Tendonitis, Quadriceps Tendonitis, Chondromalacia Patellae and Patellar Compression Syndrome.

Injury Management

The first step in injury management is to assess the severity of the injury and determine whether this athlete should continue or not. The STOP procedure allows coaches to follow steps to effectively assess the injury. All coaches should consider completing a first aid course of some sort. If not they should have people readily available who have appropriate training.

“STOP” (Don’t panic stay cool)

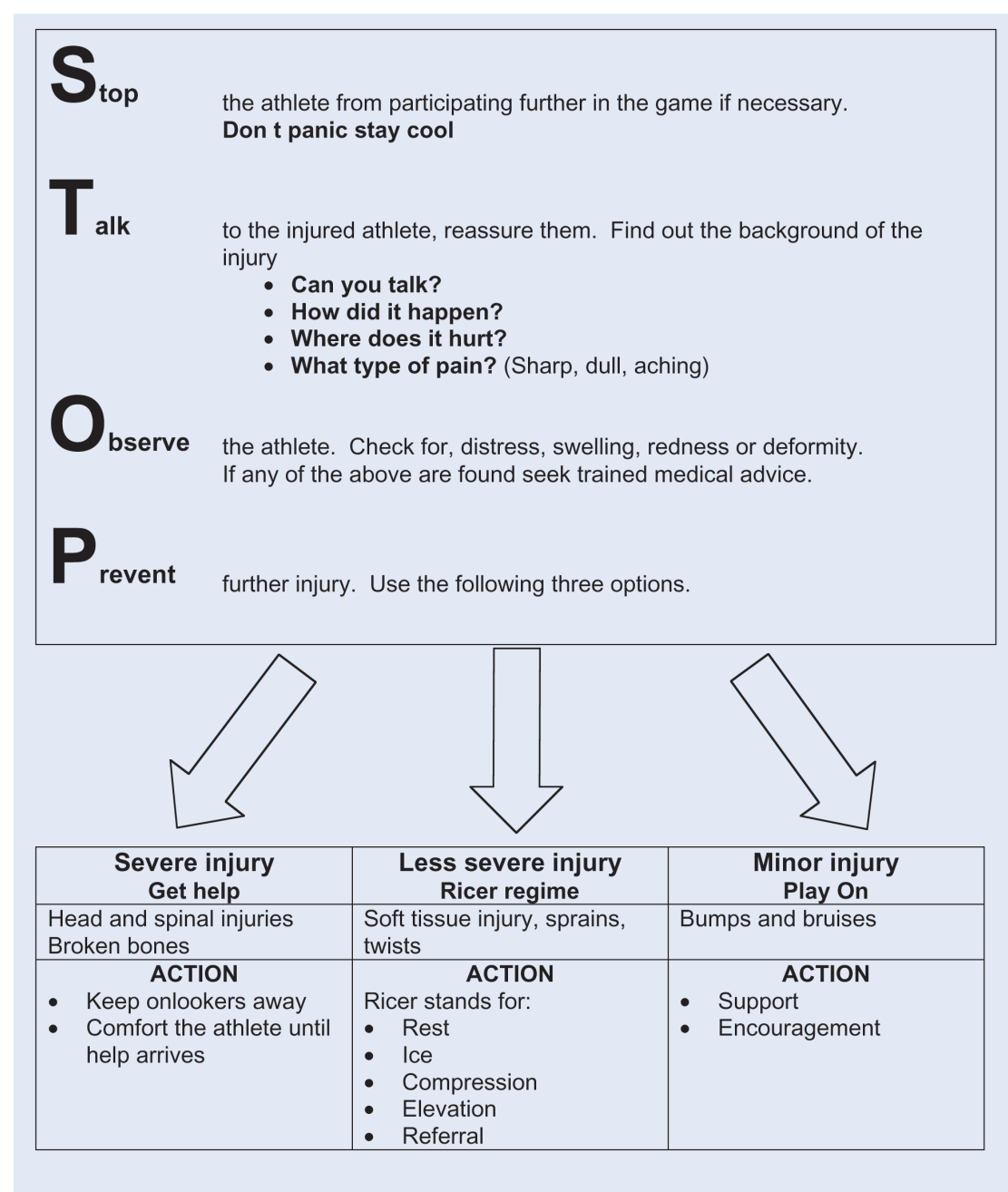

“RICER”

“Ricer” regime is used for soft tissue injuries such as ligament sprains, muscle strains and muscle haematomas (corks). It can be used for bumps and bruises that occur in sport.

Rest

Where continued involvement in the activity would promote bleeding by increased blood flow, it is essential to rest.

Ice

Reduces inflammation, pain and muscle spasm.
Apply ice for 20 minutes every two hours for the first 48 hours.

Note:

- Do not apply directly to skin
- Do not apply to people with circulatory problems
- Children have a lower tolerance to ice

Compression

Apply a firm, wide bandage over a large area covering the injured part.

This reduces bleeding and swelling and provides support for the injured part.

Elevation

Raise injured area above the level of the heart where possible.
This reduces blood flow to the injured area, which in turn reduces pain and swelling.

Referral

Refer the injured athlete to a suitably qualified doctor or physiotherapist in order to fully understand the extent of the injury and gain expert advice.

Sports Psychology

What is sports psychology? Sports psychology is about enhancing performance. This can take the form of time management and goal setting at one end of the scale, to imagery and visualization at the other.

As a coach it is important to identify the basic areas involved in sports psychology. Coaches should have a knowledge of basic techniques, which will help them to assist the athlete.

One of the characteristics of mentally tough athletes is their ability to effectively handle difficult situations. Sport is a challenge partly because it is always changing. Rarely are you confronted with exactly the same situation. Competition is really nothing more than a series of problems: Crowds, late starts, lousy officials, bad court surface. Every time a player misses a shot, turns the ball over, gives away a cheap foul, feels fatigued, or when momentum shifts in a game. Problems may be encountered anywhere.

The athletes' response to problems will bring them either success or failure as a competitor. If the athlete expects to enter the competitive arena and have everything go smoothly, they are in performance trouble. To be successful, the athlete must have a consistent positive attitude, which can be developed by you, the coach.

There will be times when your athletes will feel threatened, lack confidence or fall in a slump. In such situations they have two choices. First, they can let the situation or person dominate them and thereby take the chance of it affecting their performance. Alternatively, they can take responsibility for themselves.

The best athletes are able to consistently perform to their best, because they give themselves every opportunity to do so. They have the mental skills to turn a problem into a solution and to keep the situation in perspective.

The aim of this module on sports psychology is to introduce a number of mental skills, which your athletes can begin to learn in order to improve their mental skills.

Self-Talk

Self-talk is the internal thought processes we are continually running through our heads. It is called self-talk because it is often like having a conversation with ourselves about ourselves. If our self-talk is in touch with reality, positive and task-related, we perform well. If it is untrue, negative or defeatist, anxiety and worry results, and performance is disrupted.

Highly successful athletes program and control their self-talk and actively disallow negative thoughts to intrude upon their positive self-talk. They actually structure their self-talk so that it is both positive and related directly to the task.

Less successful athletes, on the other hand, have a greater frequency of negative thoughts usually associated with frustration, anger and impatience. Instead of having positive, task related thoughts their thoughts are negative and outcome-related.

Example

Consider two different self-talk patterns a basketball player may have when confronted by a very skilful opponent:

Player A: "Great, a challenge. A chance to test my skills. I'll need to keep low on my man.

Player B: "Oh no! They are going to beat me in front of all these people. I'm too slow. I can't"

Which player has a greater chance of success? Usually, our thoughts produce a self-fulfilling prophecy. That is, player B will be beaten because the result was expected.

Another common example is the 'mistake syndrome'. One of the most frustrating experiences on the court is making one crucial mistake, then self-talking yourself into a series of further mistakes until an entire game is ruined. Experienced athletes learn to nip the problem in the bud by using a re-focusing technique coupled with positive, task related self-talk. Inexperienced athletes on the other hand tend to react negatively by questioning their ability, becoming angry with themselves or others, or trying too hard to compensate and, in doing so, making further errors.

The athletes you coach should aim to pattern and control their self talk so as to give themselves every possible chance of consistent, high level performance. Many coaches adopt the rule that players must not make two mistakes in a row. A mistake is part of the game, but to stop and worry about it is a second mistake that a coach will not accept!

Self-talk should take two forms:

1. Positive emotive self talks

Words and phrases such as "great", "good shot", "way to go", and "c'mon you can do it"... all help to create positive emotions and reinforce their self-belief. If they hit a great shot, they should not wait for others to slap them on the back but give themselves a mental pat on the back. When they deserve it they should use positive emotive words in their self-talk.

We all like honest praise and reinforcement from others. It is important that athletes learn to praise and reinforce themselves. Others may not see that they are in a slump and in need of encouragement.

2. Talk related self-talk

When players set specific goals for training or performance they can provide a positive source for self-statements. If the performance goals you set are specific and relate to the strategies and skills you wish to implement, then the player's self talk can focus on stating those goals in a positive, self coaching manner.

Helping players become more aware of what they are thinking will help them to focus their attention on the task at hand, rather than on negative or irrelevant thoughts. For example, a common piece of coaching advice for somebody shooting is "wrist snap".

This has two effects: it reduces the amount of information the player has to think about and focuses their attention on what is required to shoot well.

It is important for players to become aware of their own self-talk and the important goals for each task. Once aware, they can write their own self-talk scripts for many situations thereby directing their attention to things positive.

In any situation you can have a variety of thoughts running through your head, some positive, some negative. The athlete needs to control what type of the thoughts they will allow to dominate.

Exercises

1. Have your players develop scripts for various situations: Free throws, joining the game for the first time, on zone defence, on man to man defence, on the bench, missing a shot.
2. Play "freeze". During training look for situations that suggest negative behaviour. Call out "freeze" or blow a whistle and stop play. Ask the player concerned whether the self- statement was negative. Ask them what they should have said.
3. "Rubber Band" - same as above, but the player has a rubber band around their wrist, which they flick whenever a negative thought comes to mind.
4. Some elite players write a key phrase on their arm, which they can look at to refocus when a negative thought comes to mind.

Body Language

The telltale signs of defeat are easy to detect. Watch any one-sided game for a period of time and the signs will be obvious. Head down and shaking of head, shoulders slumped, slow getting back on defence, slouching while waiting to be subbed. This behaviour gives the impression to those observing, that the athlete has thrown in the towel.

This is commonly known as your body language. The message you present through your body and actions. This defeatist look has the immediate effect of signaling to your opponent's how you are feeling. It may bolster their confidence and encourage them to move in for the kill. More importantly, on a personal level, there is a change in technique. A lack of emotional intensity may produce lazy footwork, erratic passing, poor shot selection and slow reactions.

The reason for these physical changes is simple and logical. Our physical state and emotional state are closely connected.

If you feel dejected, disinterested, or discouraged, then you will begin to look that way, and consequently play that way. The obvious solution to overcome this problem would be to change the way we feel. However if your opponent is playing the game of their lives, and/or you are making an uncharacteristically high number of errors, then it is extremely difficult to try to feel confident. Negative emotions are extremely overpowering.

The answer lies in the connection between our physical and emotional states. We cannot affect one without also affecting the other. When we physically change how we appear on the outside, we inevitably display corresponding changes psychologically and emotionally. So if you want to feel strong or determined, then pretend to look strong or determined.

It is like wearing a mask to cover your true feelings. However when people put on a mask they also tend to become the character which that the mask is portraying. When a child pretends to be his or her favorite superhero, for all intent and purposes, they are that superhero. They look, and consequently feel stronger, more powerful and able to achieve much more.

To emphasise the importance of the image you project, have the players think of their favourite players whom they would regard as confident and determined at all times. Players such as Michael Jordan, Andrew Gaze or Lauren Jackson come to mind. These players have a powerful physical presence. They physically project determination, confidence and strength. The way they walk, carry their head, their shoulders, and so forth, all contributes to that image.

Which players would you prefer to be playing, a player with an aura of confidence, or a player with all the telltale signs of a loser? Get your athletes to put themselves in their opponent's position and ask them who would the opponents prefer to be playing.

The choice is theirs. If they are feeling like a loser, start by getting them to look like a winner and soon they will feel like a winner, and play like a winner. In other words; fake it until you make it!

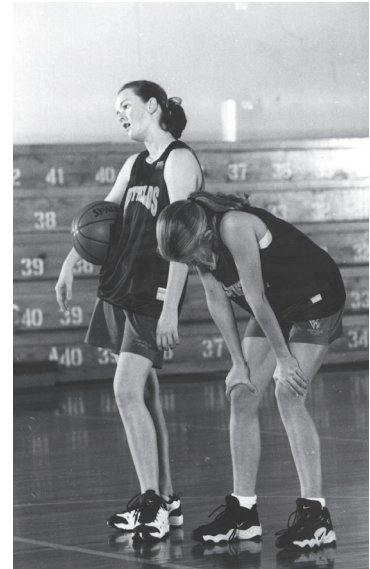

Exercises:

1. Have the team or player think of the image they want to project, then decide how that image would best be achieved. If they have problems deciding, have them think of those players whom they consider to have a presence they admire, and pick out what it is about their body language that gives this impression.
2. Once this has been done, have them pretend during training to be someone who has the image they desire, this may be the player they chose in the previous exercise. Video is very useful for feed back.

Imagery

All young players have the 'skill' of daydreaming. Often they do it when they should be attending to other matters. In a sense they are using mental imagery.

Imagery, in the sport context, is the non-physical practice of motor skills. The difference between daydreaming and imagery is similar to the difference between shooting around for enjoyment and doing a training drill. Both will produce results but the more disciplined imagery or training drill will show greater, more specific improvement.

Unfortunately, most players don't use enough of this type of training, or they don't use it systematically and fail to get the most benefit from it.

The secret behind imagery lies in the inability of our brain to differentiate between the physical performance of an action and our imaging the performance of that action. When you perform a physical activity, such as a free throw, the brain sends electrical signals to the muscles and initiates action. If you imagine shooting a free throw, the same electrical signals are sent, but at a reduced intensity, insufficient to cause muscle movement. The motor program for that movement is reinforced however.

To get the most benefit it is important that the images the players produce are as much like the real thing as possible. That is, they should use as many senses as possible. If they are imaging a free-throw, they should hear the noise of the crowd, the squeak of their boots, see the basket and the players standing around the key, feel the ball in their hands, and the smoothed relaxed motion of a good shot - and, "swish". See and hear it go in.

Exercises:

1. **Technique:** Have your players exercise the skill just before they perform it - Mentally practice the skill after they have performed an ideal execution of that skill.
2. **Training drills:** Players imagine they are in a game situation, and play at the appropriate intensity and with total concentration. That is what is meant by QUALITY practice. Imagine they are a particular player with the appropriate body language.
3. **Learning plays:** Imagine the X's and O's to be players. It will help the players to remember more easily. Imagine making the cuts and screens as they would be made on any successfully executed play.
4. **Bench:** See themselves as the players they will replace, working on each opponent's weaknesses.
5. **Mistakes:** Visualize what they should have done, not what they just did wrong.

Attitude

The attitude that your players carry with them onto the court can have a strong effect on their performance. Obviously a positive attitude is important and this can be addressed by the mental skills discussed in this module. But it is the attitude towards winning and losing that can have a stronger affect and severely effect performance, unless handled correctly.

Outcome focus

In society there is still a strong belief that winning is the only thing that matters. Athletes who carry this attitude will often fail when the game hangs in the balance. These athletes are pre-occupied with winning, beating a certain opponent, making a representative team and impressing coaches and friends. They are often easily distracted. Secondly they place an enormous amount of pressure on themselves. Unless they know how to control this pressure, it will have an adverse effect on their performance.

Process focus

Successful athletes focus more on the doing, or the process. Their aim is to play to the best of their ability and this is achieved by having their minds on the job, and knowing what their job is.

By focussing on the outcome, the player may adversely affect the process, but if they focus on the process, the outcome will take care of itself. Winning is a bonus and is a result of focussing on the process and playing well. If they lose or play badly they are secure in the knowledge that they did the best they could and can now focus on trying to improve in future.

For example, an athlete who is taking foul shots at the end of the game might focus on "lock" and "snap". This is likely to be more successful than focussing on "I must make this shot to win."

Exercises:

If athletes are too outcome focused, ask them WHAT they want to achieve (the outcome). Then ask HOW they are going to achieve this outcome (the process). Then have them focus on achieving the process. Have them realise the outcome will happen as a result of the process.

If you can instill in your athletes the right attitude and teach them the skills of self-talk, body language, imagery and attitude, your athletes are on the way to becoming mentally tough. It is important, however, to stress to your athletes that these four areas are under their control. Too many athletes are in the habit of saying, "I just had a bad day". They need to accept responsibility for their actions and realise they have control over their self-talk, body language, images, and attitude. Just as important is the fact that they are skills and, just as with physical and technical skills, they need to be practiced on a regular basis. The reason for the exercises is so they can be incorporated into training and not be something separate. Whenever an athlete competes, their mind and body work together. The same applies during practice.

GLOSSARY OF TERMS

Air ball	A shot that misses the basket and backboard
Assist	A pass that immediately results in a score for a teammate
Alley Oop	A pass resulting in a player catching it in the air and shooting the ball before landing
Backboard	Rectangular or fan-shaped board behind the basket
Back court	The half of a court furthest from the basket a team is attacking
Back door cut	A cut to the basket made behind a defender
“Ball”	A word used by a defender whose player is in possession of the ball and has not dribbled or is still dribbling. This is to alert team mates the ball can be, or is being dribbled and that the person calling “ball” will defend that player.
Ball side	The side of the court where the ball is
Ball handling	Dribbling, passing and receiving
Banana Cut	When leading to the perimeter the offensive player may start to turn to face the passer. This is done when the defender is behind the leading player and they will step into the path of the defender. It also makes facing the basket easier as it will require only a 90 degree turn.
Bank shot	A shot where the backboard is used
Baseball pass	Used to pass over longer distances where the ball is thrown in a similar action to a baseball
Baseline	The end-line located behind each basket
Baseline Pivot Foot	Foot that is closest to the baseline
Big to Bigger Footwork	Used in a protection dribble and also in defence. The athlete’s feet are shoulder width apart (“big”) and they step in the direction they are going (to “bigger”) and then move their second foot back to shoulder width.
Block	Area on the edge of the key towards the baseline – sometimes referred to as “low post”. “Block” also refers to the action of blocking shots.
Blocking foul	A foul which occurs when a player impedes the movement of opponent
Blocking out	Used to keep an opponent away from the basket by gaining position between the basket and an opponent in a rebounding situation. Also referred to as Boxing Out.
Blocked shot	Deflection of a shot by a defender when the ball is on its upward trajectory
Body balance	Controlling the physical movement of the body while executing basketball skills
Bonus	Once a team has incurred four fouls in a quarter, for each foul they commit (unless it is an offensive foul) after that the opposition get two foul shots.
Bounce pass	A pass that bounces before it reaches the receiver
Boxing out	See “blocking out”
Catch Fake	A potential receiver puts their hands up to make the defender think a pass has been, or is going to be, made.
Carry	A violation committed by a dribbler where the dribbling hand moves under the basketball momentarily holding or carrying it while dribbling
Centre	Also known as the 5 spot player or “5 man”, primarily a tall player who plays close to the basket. Skills required to play this position include rebounding, inside shooting, and receiving.

Change of pace	An offensive technique where a player changes from a slow speed to a fast speed or vice versa in an effort to free themselves from a defensive opponent.
Charging foul	An offensive foul which results from an offensive player contacting a defensive player who has established legal defensive position
Chest pass	A two-handed pass thrown from the passer's chest to the receiver's chest
Controlling the boards	The team that clearly takes the majority of rebounds
Crashing the boards	Going aggressively for rebounds
Cross-court pass	A pass that is thrown from one side of the court to the other, rather than down the court towards the basket. Also known as a "Skip" pass.
Crossover step	A step used by an offensive player in changing direction past a defensive opponent. The player steps across their body (eg stepping to the left with their right foot).
Crossover dribble	A dribble where the ball is moved from one hand to the other in front of the body as the dribbler changes direction
Cut	A quick movement by an offensive player to free themselves from an opponent. Cutting usually involves a sharp change of direction and pace
"D"	Shortened term for "defence
Dead ball	When the ball is not in play
"Dead"	A word used by a defender defending the ball to alert team mates that the player has picked up their dribble
Defence	The team that is not in possession of the ball
Defensive rebound	A rebound taken by the defence
Defensive transition	The recovery of players from offence to defence to prevent a quick, high percentage shot from the offence
Denial stance	Defensive position, when the defender has their back to the player with the ball. This is used when their player is close to the ball and it is important that the defender can still see the player with the ball. Also referred to as a "Closed" Stance
Double dribble	A violation that occurs when a player dribbles with two hands, or stops dribbling and then dribbles again
Double team	A defensive term used when two players, defend the player with the ball
Dribble	Bouncing the ball so that it remains in a player's possession. Used to advance the ball down the court and must be executed using one hand at a time
Drive	A quick dribble at the basket in an effort to score
Drive fake	A short step taken by an offensive player who has the ball to make the defender think they are going to drive. Also called a Jab Step
Dunk	A dunk, or "slam dunk" involves dropping the ball into the basket from directly above the rim
Elbow	Where the foul line meets the side of the key
End line	As for "Base line"
Fake	A offensive movement used to make the defence react as if the offence was to pass, shoot or drive.
Fast break	An offensive situation where a team suddenly gains possession and attempts to move the ball up the court quickly so as to outnumber the defence and provide an open player for a high percentage shot.
Field goal	A basket scored on any other shot other than a free throw. This shot would be worth either 2 points, or, if taken from behind the 3 point line, 3 points.

Filling the lanes	A term used when a team is in offensive transition or on a fast break. These hypothetical lanes provide court balance, spreading offensive players across the court
Floor balance	An important offensive principle where players occupy important areas of the court.
Follow through	An important aspect of both shooting and passing, where the player continues their momentum after releasing the ball, improving accuracy of the skill performed.
Forward	Also referred to as a 3 or 4 spot player or "3 or 4 man". Positions usually filled by two of the taller players requiring strong shooting and/or inside moves and rebounding skills.
Foul	A violation resulting from illegal contact with an opponent causing disadvantage.
Foul line	A line at the top of the key 4.6m from the basket. It is used for both foul shots. Also referred to as the free throw line.
Foul line extended	This is an imaginary line extending the foul line out to the side line.
Free throw	An unguarded shot taken from behind the foul line generally after a technical foul or a foul committed on a shooter. See also "bonus".
Front court	The end which the offensive team is attacking, termed the "offensive end"
Full court press	A style of defence where the defensive team guards its opponents over the full length of the court. This term can refer to both man to man and zone defensive principles.
Give and go	Also referred to as a pass and cut. This is where an offensive player passes to a team mate and immediately cuts to the basket looking to receive the ball back.
Goal tending	When a defensive player touches the ball when a shot is on its downward trajectory. The score automatically counts if this occurs.
Help side defence	A player who is defending opposite the side of the court to the ball. Defenders should provide help, assisting their team mate defending the ball.
High Pivot foot	A player's foot that is closest to half way. Also called the "Outside Pivot Foot".
High post	An offensive position around the foul line.
Hoop	Another term used for the ring or basket.
Inside Pivot Foot	The player's foot that is closest to the centre of the court.
Jab step	A drive fake.
Jump ball	This is the procedure used to commence the start of the game.
Jump shot	A shot taken as a player jumps.
Jump stop	A method of stopping where both feet land simultaneously allowing the player to pivot with either foot.
Key	The area below the foul line to the baseline.
Lay up	A shot taken close to the basket while a player is on the move.
Lead pass	A pass thrown to a receiver, so that it can be caught while on the run.
Low post	See "block"
Man to man defence	Team defence where each player has the responsibility of defending a particular opponent on the court.
Offence	The team which has possession of the basketball. Also refers to methods of team play, which generally involves a structured pattern of play.
Offensive rebound	A rebound taken by the shooter or one of the shooter's team mates.
Offensive transition	The quick movement of players from defence to offence after gaining possession of the ball, with the aim of securing an early high percentage shot.

Off guard	Also referred to as a "shooting guard" a "2 spot" player or "2 man". This player has the responsibility of assisting the point guard in bringing the ball up the court and has a primary role as a perimeter shooter in offence.
Open Stance	Defensive stance when the defender has their back to the basket.
Outlet pass	The first pass made after a defensive rebound which starts the offensive team off into offensive transition or fast break opportunities.
Outside Pivot Foot	The foot closest to the sideline
Over and back violation	A violation that occurs when the offensive team returns the ball into the back court once it has entered in the front court.
Overhead pass	A two-handed pass thrown from above the forehead.
Overtime	An extra period that is played as a result of a draw at the end of a game..
Pass and cut	See "give and go".
Passing lane	An imaginary path from the passer to a potential receiver.
Percentage shot	A shot taken close to the basket is a high percentage shot, while one further out is a lower percentage.
Peripheral vision	Perception of activity beyond that which is directly under focus.
Personal foul	A foul which is committed by a player
Pick	An offensive technique where one player legally blocks the path of a defender in order to free a teammate. It is also referred to as a 'screen'.
Pick and roll	An offensive technique where a player sets a screen for a team mate with the ball and then pivots, or rolls, to receive a pass
Pivot	A body movement fundamental where a player keeps one foot stationary and steps with the other.
Pivot Foot	The foot that remains on the ground when pivoting. Players need to be able to pivot on either foot. Coaches use a variety of terms to describe which foot to pivot on when completing particular moves (eg Inside Pivot Foot, High Pivot Foot)
Point guard	Also referred as the "1 spot" or "1 man". A player whose responsibilities include, initiating and setting up the offences, and bringing the ball up the court. Point guards should possess excellent ball handling and passing ability.
Post	An offensive position close to the basket
Possession Arrow	When two players simultaneously have possession of the ball, a 'jump ball' is called. The possession arrow determines which team will be given the ball to inbound from the sideline (a jump ball is no longer taken). Whichever team does not get possession of the ball after the jump ball to start the game has the "possession arrow". This means they will get the ball on the next jump ball situation, and the possession arrow then changes to the other team.
Press	A defensive tactic used to pressure opponents either in the full court, 3/4 court, 1/2 court and 1/4 court
Rebound	The gaining of possession following a missed shot
Screen	See "pick"
Screen and roll	See "pick and roll"
Scrimmage	A practice game of basketball
Second shot	A shot which follows shortly after an offensive rebound
Set shot	A shot taken from a stationary position where both feet stay in contact with court

Shuffle	A term used to describe the lateral footwork of a defender playing defence. Also called "slide" or "big to bigger" footwork
Side line	Lines running along each side of the court meeting the two baselines
Skip pass	A pass made from one side of the court to the other, often across the key
Speed dribble	A method of dribbling used to advance the ball quickly up the court. A higher dribble which is pushed out in front of the dribbler
Split Line	An imaginary line from one basket to another, which is used in teaching man to man team defensive concepts. Also referred to as the "Help" Line.
Squaring up	Positioning of the body so that the feet and shoulders are facing the basket
Stride stop	A method of stopping where the feet land in a "1-2" sequence with the first foot braking the forward motion and the second foot stepping forward to achieve a balanced final position. When they have the ball the first foot contacting the floor is the pivot foot.
Strong side	Side of the court where the ball or most players are located
Substitution	A player who replaces a fellow team mate
Swing the Wings	Where two offensive players on opposite sides of the court, cut to swap sides.
"Switch"	A word used by two defenders in a man to man situation to combat a screening situation. The two players would swap opponents
Technical foul	A foul called on a player, coach or official by a referee for some form of unsportsmanlike conduct
Eight second violation	A violation called when the offensive team takes longer than eight seconds to move the ball out of the back court
Three second area	Also called the "key". An offensive player can only spend three seconds in this area at one time
Three seconds	The violation called on an offensive player who exceeds the three second period in their own offensive key
Time out	A 60 second time period during which play is stopped and teams discuss strategy
Trailer	An offensive player who follows the initial fast break down court
Transition	The quick movement of players from offence to defence or defence to offence when ball possession has changed. See Defensive Transition and Offensive Transition
Trap	Two players defend one opponent
Travel	Taking more than one step without dribbling the ball.
Triple-threat	Also known as the ready position. This position requires a low and balanced stance, allowing the offensive player to shoot, drive or pass
Turn-over	Losing possession without a shot being attempted
Unsportsmanlike foul	A player who fouls in an intentional fashion and is not considered in the spirit of the game.
Violation	An infringement of the rules that is not a foul. This will result in a change of possession with the opposing team receiving the ball to throw in from the sideline.
Warm-Up	Activity prior to training and/or games that increases blood flow to assist players to be physically prepared for the upcoming activity.
Weak side	The side of the court away from the ball where there are fewer players
Wing	See "foul line extended"
Zone defence	This is a team defence in which players are responsible for defending an area on the court and the players within that area
Zone Offence	A pattern or series of plays designed to counter a zone defence

INDEX

There are currently 5 booklets in the "Basketball Coaching Made Easy" series.
 Book 1: Introduction, Role of the Coach, Inclusive Coaching and Sports Science
 Book 2: Individual Body Movement and Ball Skills
 Book 3: Individual Offensive and Defensive Skills
 Book 4: Team Offensive and Defensive Skills
 Book 5: Training Drills

Subject	Book	Page
Athletes		
<i>Evaluating Skill Performance</i>	1	31
Athletes with an Intellectual Disability		
<i>Skills Required</i>	1	42
<i>Tips for Coaching</i>	1	42
Athletes with a Disability		
<i>Communication</i>	1	40
<i>Developing inclusive philosophy</i>	1	36
<i>Planning to Include</i>	1	37
Attitude	1	59
Ball handling	2	13
Ball Handling Drills		
<i>Around the head</i>	2	14
<i>Around the waist</i>	2	14
<i>Blurr</i>	2	14
<i>Double Leg - Single Leg</i>	2	15
<i>Figure Eight Leg Wrap</i>	2	14
<i>Figure Eight with one bounce</i>	2	15
<i>Figure Eight Speed Dribble</i>	2	15
<i>Waist & Leg Rhythm drill</i>	2	15
<i>Spider drill</i>	2	15
<i>Straddle Flip</i>	2	14
<i>Two ball alternating drill</i>	2	14
<i>Two bounce drill</i>	2	15
Back Cut	3	13
Ball movement	4	17
Ball reversal	4	17
Ball reversal against zone	4	40
Ball Screen	4	24
Banana Cut	3	11
"Big to Bigger" Defensive Footwork	3	23
Body movement	2	6
<i>Changing direction</i>	2	9
<i>Jump stop</i>	2	11
<i>Jumping</i>	2	7
<i>Pivoting</i>	2	12
<i>Running</i>	2	8
<i>Stopping</i>	2	10
<i>Stride Stop</i>	2	10
Body Movement Fundamental Drills	4	17
<i>Stop and pivot Drill</i>	4	17
<i>Clover leaf Pivot Drill</i>	4	18
<i>Corridor Drills</i>	4	18
Body Language	1	60
Catching	2	31
Close Out Technique	3	28
Coaching		
<i>Coaching Styles</i>	1	18
<i>Demonstrating Skills and Drills</i>	1	27
<i>Developing Coaching Philosophy</i>	1	19
<i>Effective Communication</i>	1	20
<i>Evaluating Skill Performance</i>	1	31
<i>Organising Athletes</i>	1	28

Subject	Book	Page
<i>Organising Drills</i>	1	30
<i>Planning</i>	1	21
<i>Role of the Coach</i>	1	17
<i>Teaching Athletes with Disabilities</i>	1	36
<i>Ten Important Duties</i>	1	34
Combination Drills	4	21
<i>Thomas Drill</i>	4	21
<i>Tennessee Drill</i>	4	22
Communication	1	20
Concept Shooting	5	14
Conditioning Circuit	1	52
Continuity Offence	4	28
Corridor Work	1	30
Court balance and player spacing	4	16
Creating a lead for the ball	3	10
Cross Screen	4	25
Cuts		
<i>Back</i>	3	13
<i>Banana</i>	3	11
<i>Flash Cut</i>	4	20
<i>Seal and Lead</i>	3	12
<i>Shallow Cut</i>	4	23
<i>V-cut</i>	3	10
Cutting Off Screens		
<i>Back cut</i>	4	26
<i>Curl cut</i>	4	26
<i>Flare or replace</i>	4	26
<i>Straight cut</i>	4	26
Defence	4	56
<i>Ball-You-Man</i>	4	56
<i>Flat triangle</i>	4	56
<i>Hedging</i>	4	57
<i>Help and recover</i>	4	57
<i>Jump to the ball</i>	4	58
<i>Split Line</i>	4	57
Defensive Communication	4	65
Defensive Footwork (see Individual Defence)		
Defensive Rebounding	3	8
Defensive Rotation	4	60
<i>Drills to practice rotation</i>	4	62
<i>Switching rotations</i>	4	61
Down Screen	4	25
Dribble Entry		
<i>Against Zone Defence</i>	4	42
<i>Motion Offence</i>	4	23
Dribbling	2	16
<i>Behind the back</i>	2	21
<i>Between the legs</i>	2	22
<i>Crossover</i>	2	20
<i>Fake crossover</i>	2	24
<i>Hesitation</i>	2	19
<i>On-side</i>	2	24
<i>Protection</i>	2	18
<i>Reverse</i>	2	23
<i>Speed</i>	2	17

Subject	Book	Page
<i>Dribbling Drills</i>	5	11
<i>Corridor dribbling</i>	5	11
<i>Dribble knockout</i>	5	11
<i>Dribble race</i>	5	13
<i>Dribble tag</i>	5	12
<i>Follow the leader</i>	5	13
<i>Massed dribbling Drill</i>	5	12
<i>Obstacle dribble</i>	5	12
Drive Fake	3	14
Drop Step	3	24
Fitness		
<i>Components of Fitness</i>	1	46
<i>General Conditioning Circuit</i>	1	59
<i>Principles of Training</i>	1	47
Flash Cut	4	20
<i>Defending a Flash Cut</i>	4	59
Flat Triangle	4	56
Fluid Replacement	1	54
Freeze Dribble	4	42
Gapping the Zone	4	41
Group Work		
<i>How to Form Small Groups</i>	1	28
<i>Moving from One Drill to the Next</i>	1	29
Hedging	4	57
History of Basketball	1	7
Individual Defence	3	21
<i>Big to bigger</i>	3	23
<i>Close out technique</i>	3	28
<i>Defending the Back Cut</i>	3	27
<i>Defending the dribbler</i>	3	26
<i>Drop step</i>	3	24
<i>Footwork</i>	3	23
<i>Slide, Run, Slide</i>	3	25
<i>Stance</i>	3	22
Individual Defence Drills		
<i>Back Cut/Forward Lead Denial Drill</i>	5	24
<i>Close out Drill</i>	5	24
<i>Forward Lead Denial Drill</i>	5	24
<i>Mass Defensive Slide Drill</i>	5	23
<i>Mirror Drill</i>	5	23
Individual Offence	3	5
<i>Moves</i>	3	14
<i>Drive Fake Series</i>	3	14
<i>Drive, Fake and Drive</i>	3	14
<i>Drive, fake and crossover</i>	3	16
<i>Drive, fake and shot</i>	3	17
<i>Shot Fake Series</i>	3	18
Individual Offence Drills		
<i>Forward Lead Drill</i>	5	25
<i>Mass Individual Offensive Moves</i>	5	25

Subject	Book	Page
Injuries		
<i>Common Basketball Injuries</i>	1	55
<i>Injury Management</i>	1	56
<i>Injury Prevention</i>	1	53
Jab Step (see Drive Fake)		
Jump to the ball	4	48
Lay-up	2	35
<i>Breakdown for teaching</i>	2	36
Leading (see Cuts)		
Legal Responsibilities of Coaching	1	33
Man to Man Offence	4	15
Motion Offence		
<i>3 Out, 2 In</i>	4	34
<i>4 Out, 1 In</i>	4	36
<i>5 Out</i>	4	38
<i>Motion for younger players</i>	4	33
<i>Pass and cut</i>	4	18
<i>Pass, cut and replace</i>	4	19
<i>Penetration</i>	4	21
<i>Player movement without the basketball</i>	4	17
<i>Receiver Positions</i>	4	21
Offence		
<i>Building an Offence</i>	4	18
<i>Continuity Offence</i>	4	28
<i>Man to Man Offence</i>	4	15
<i>Motion Offence</i>	4	30
Offensive Rebounding	3	9
Outcome Focus	1	62
Pass and cut	4	18
Pass, cut and replace	4	19
Passes		
<i>Baseball</i>	2	29
<i>Bounce</i>	2	27
<i>Chest</i>	2	26
<i>One hand push</i>	2	28
<i>Overhead</i>	2	30
Passing and receiving	2	25
Passing Drills		
<i>2 ball Drill</i>	5	10
<i>3 lanes Drill</i>	5	10
<i>3 man weave Drill</i>	5	9
<i>Circle Drill</i>	5	9
<i>Deflections Drill</i>	5	9
<i>Five Star Passing Drill</i>	5	7
<i>Four Corner Passing Drill</i>	5	6
<i>Pepper Drill</i>	5	6
<i>Scattered circle passing Drill</i>	5	7
<i>Three corner passing Drill</i>	5	8
Perimeter Players		
<i>3 Out, 2 In</i>	4	34
<i>4 Out, 1 In</i>	4	36
Pivot Foot	3	13
Playing Positions	1	9

Subject	Book	Page
Planning	1	21
<i>Developing a Season Plan</i>	1	22
<i>Elements of a Practice Session</i>	1	22
<i>Managing Efficient Training Sessions</i>	1	32
<i>Organising Athletes</i>	1	28
<i>Sample Coaching Plan</i>	1	25
Post Players		
<i>3 Out, 2 In</i>	4	35
<i>4 Out, 1 In</i>	4	37
<i>Post Flash Cut</i>	4	44
<i>Post movement</i>	4	44
<i>Post play</i>	4	42
<i>Post positions</i>	4	42
<i>Short Corner</i>	4	44
Process Focus	1	62
Psychology	1	58
Rebounding	3	7
<i>Defensive</i>	3	8
<i>Offensive</i>	3	9
Rebounding Drills		
<i>Circle Block out Drill</i>	5	19
<i>Help side Block out Drill</i>	5	20
<i>Mass block out Drill</i>	5	18
<i>One on One/Two on Two Close out and Rebound Drill</i>	5	20
<i>Rebound/outlet Drill</i>	5	21
<i>Sandwich or Hamburger Drill</i>	5	20
<i>Two player block out Drill</i>	5	19
Receiver Positions	4	21
Referees		
<i>Coach Referee Relations</i>	1	33
Reverse Pivot	3	13
RICER	1	57
Rules of the Game		
<i>Personal Fouls</i>	1	15
<i>Technical Fouls</i>	1	16
<i>Violations</i>	1	13
Screens	4	24
<i>Cross screen</i>	4	25
<i>Cutting Off Screens</i>	4	26
<i>Down screen</i>	4	25
<i>On Ball Screen</i>	4	24
<i>Screen away from the ball</i>	4	25
<i>Up screen</i>	4	25
Shell Drill	5	26
Shooting	2	32
<i>Jump shot</i>	2	37
<i>Lay-up</i>	2	35
<i>Set shot</i>	2	34
Shooting drills	5	14
"21"	5	15
<i>3, 2, 1 shooting Drill</i>	5	16
<i>Cinciannati lay-up Drill</i>	5	14

Subject	Book	Page
<i>Continuous shooting Drill</i>	5	16
<i>Plyometric shooting</i>	5	14
<i>Rapid fire shooting Drill</i>	5	17
<i>Three in a row</i>	5	15
<i>X-out Lay Ups</i>	5	16
Shot Fake	3	18
Shot selection	4	18
Split Line Defence	4	57
Spacing	4	16
Sports Psychology		
<i>Attitude</i>	1	62
<i>Body Language</i>	1	60
<i>Imagery</i>	1	61
<i>Self Talk</i>	1	59
Sports Safety	1	53
Stretches	1	51
Station Work	1	30
STOP	1	56
Team Defence	4	55
<i>Away from the basketball</i>	4	58
Team Offences	4	28
<i>Continuity</i>	4	28
<i>Flex</i>	4	29
<i>Motion</i>	4	30
<i>Pass and cut</i>	4	29
<i>Putting an Offence together</i>	4	33
<i>Sets</i>	4	31
<i>Teaching to younger players</i>	4	32
Transition Defence	4	12
<i>3 on 2, 2 on 1 Drill</i>	5	29
<i>3 on 2 Fast Break Drill</i>	5	28
<i>Change Drill</i>	5	29
<i>Defending a 2 on 1 situation</i>	4	13
<i>Defending a 3 on 2 situation</i>	4	14
Transition Offence		
<i>2v1</i>	4	10
<i>3v2</i>	4	11
<i>Driving lane</i>	4	8
<i>Passing lane</i>	4	8
TREE Principle	1	38
Up Screen	4	25
V-Cut	3	10
Warm Up	1	23
	1	54
Wheelchair Basketball		
<i>Offensive Adaptations</i>	1	43
<i>Points classification</i>	1	44
<i>Rebounding</i>	1	44
<i>Rule Variations</i>	1	44
<i>Technical Variations</i>	1	43
<i>Tips for Coaching</i>	1	45

Subject	Book	Page
Zone Defence	4	66
<i>Alignments</i>	4	67
Zone Offence		
<i>Break Down Drills</i>	4	51
<i>Developing a Zone Offence</i>	4	46
<i>Dribbling against a Zone</i>	4	41
<i>Even Front Zones</i>	4	41
<i>Gapping the Zone</i>	4	41
<i>General Principles</i>	4	52
<i>Individual Offensive Fundamentals</i>	4	39
<i>Odd Front Zones</i>	4	41
<i>Overloading</i>	4	45



